

**SECTION 1 – REQUIREMENTS**1 *GENERAL*

This Section contains the Requirements for compliance with JAR-26.

2 *PRESENTATION*

- 2.1 The requirements of JAR-26 are presented in two columns on loose pages, each page being identified by the date of issue or the Change number under which it is amended or reissued.
- 2.2 Sub-headings are in italic typeface.
- 2.3 Explanatory Notes not forming part of the requirements appear in smaller typeface.
- 2.4 New, amended and corrected text will be enclosed within heavy brackets until a subsequent 'Change' is issued.

INTENTIONALLY LEFT BLANK

## SUBPART A – GENERAL

JAR 26.2 (continued)

**JAR 26.1 Applicability**

(a) This JAR-26 prescribes specific additional airworthiness requirements with which operators must ensure that compliance has been established if operating in accordance with the Part of JAR-OPS relevant to the particular type of operation –

- (1) Subpart B relates to Commercial Air Transportation (Aeroplanes);
- (2) Subpart C relates to General Aviation (Aeroplanes);
- (3) Subpart D relates to Commercial Air Transportation (Helicopters); and
- (4) Subpart E relates to General Aviation (Helicopters).

(b) The requirements of JAR-26 are applicable as follows –

- (1) For Subpart B from 1 October 1999, unless otherwise indicated;
- (2) Reserved;
- (3) Reserved;
- (4) Reserved.

(c) Until the final implementation of JAR-26, current national aviation requirements apply.

**JAR 26.2 Terminology**

*'Airworthiness Exemption'*: An exemption to an airworthiness requirement granted by a National Authority in accordance with its Type Certification Procedures. It is not meant to include those exemptions granted in accordance with JAR-OPS 1.010 or 3.010.

*'Manufactured'*: The date on which the inspection records show that an aircraft is first in a condition for safe flight. (See IEM No. 1 to JAR 26.2)

*'Maximum Certificated Passenger Seating Capacity (MCPSC)'*: The maximum number of passenger seats, excluding crew seats, approved during type certification of the aircraft, and specified in the Type Certificate Data Sheet. (See IEM No. 2 to JAR 26.2)

*'Maximum Approved Passenger Seating Configuration (MAPSC)'*: The maximum passenger seating capacity of an individual aeroplane, excluding pilot seats or flight deck seats and cabin crew seats as applicable, used by the operator, approved by the Authority and specified in the Operations Manual.

*'Type Certificated (TC)'*: Reference to when an aircraft was type certificated means the date of TC issuance, or equivalent, in the country of origin (i.e. the State where the first TC was issued).

**JAR 26.3 Equivalent Safety Findings (ESF)**

(See IEM 26.3)

Equivalent Safety Findings included in the Type Certification basis of an aircraft made and accepted by the national Authority remain valid regarding JAR-26 or equivalent requirements.

**JAR 26.5 Airworthiness Exemptions**

(See IEM 26.5)

(a) *Previously Granted Airworthiness Exemptions*: Airworthiness Exemptions granted, regarding JAR-26 or equivalent requirements, to an aircraft's Type Certification Basis, C of A documentation or Operations approval documentation prior to the implementation of this JAR-26 (as appropriate in each State), are to be notified to his Authority by the AOC holder who is adding an aircraft to his fleet, when that aircraft is being moved from one JAA registry to another.

(b) *Airworthiness Exemptions granted after JAR-26 implementation*: After the date of JAR-26 implementation requests for Airworthiness Exemptions regarding JAR-26 requirements, will be made in accordance with the applicable JARs for certification or operations. In the case of such jointly agreed airworthiness exemptions, there is no additional reporting requirement to the NAA.

INTENTIONALLY LEFT BLANK

## SUBPART B – COMMERCIAL AIR TRANSPORT (AEROPLANES)

## EMERGENCY PROVISIONS

**JAR 26.100 Location of emergency exits**

(Text derived from: JAR 25.807(d)(7) at Chg. 13 plus Amdt 93/1, 8/3/93)

Except for aeroplanes having an emergency exit configuration installed and approved prior to 1 April 1999, an operator shall not operate a large aeroplane having a MAPSC of more than 19 with an emergency exit deactivated, when such a deactivation results in an emergency exit being more than 18.288 m (60 feet) from any adjacent passenger emergency exit on the same side of the same deck of the fuselage, as measured parallel to the aeroplane's longitudinal axis between the nearest exit edges.

**JAR 26.105 Emergency exit access**

(Text derived from: JAR 25.813(d) to (f) at Chg. 8, 30/11/81)

An operator shall not operate a large aeroplane that does not comply with the following –

(a) Reserved

(b) If it is necessary to pass through a passageway between passenger compartments to reach any required emergency exit from any seat in the passenger cabin, the passageway must be unobstructed. However, curtains may be used if they allow free entry through the passageway.

(c) No door may be installed in any partition between passenger compartments.

(d) If it is necessary to pass through a doorway separating the passenger cabin from other areas to reach any required emergency exit from any passenger seat, the door must have a means to latch it in the open position. The latching means must be able to withstand the loads imposed upon it when the door is subjected to the ultimate inertia forces, relative to the surrounding structure, prescribed in JAR/FAR Part 25.561(b), or equivalent, at the change/amendment level specified in the relevant Type Certificate Data Sheet, or equivalent document.

**JAR 26.110 Emergency exit markings**

(Text derived from: JAR 25.811(a) to (d), and (f)&(g), Chg. 8, 30/11/81, and JAR 25.811(e) at Chg. 14, 27/5/94)

An operator shall not operate a large aeroplane after 1 April 2001, that does not comply with the following –

(a) Each passenger emergency exit, its means of access, and its means of opening must be conspicuously marked.

(b) The identity and location of each passenger emergency exit must be recognisable from a distance equal to the width of the cabin.

(c) Means must be provided to assist the occupants in locating the exits in conditions of dense smoke.

(d) The location of each passenger emergency exit must be indicated by a sign visible to occupants approaching along the main passenger aisle (or aisles). There must be –

(1) A passenger emergency exit locator sign above the aisle (or aisles) near each passenger emergency exit, or at another overhead location if it is more practical because of low headroom, except that one sign may serve more than one exit if each exit can be seen readily from the sign;

(2) A passenger emergency exit marking sign next to each passenger emergency exit, except that one sign may serve two such exits if they can both be seen readily from the sign; and

(3) A sign on each bulkhead or divider that prevents fore and aft vision along the passenger cabin to indicate emergency exits beyond and obscured by the bulkhead or divider, except that if this is not possible the sign may be placed at another appropriate location.

(e) The location of the operating handle and instructions for opening exits from the inside of the aeroplane must be shown in the following manner –

(1) Each passenger emergency exit must have, on or near the exit, a marking that is readable from a distance of 762 mm (30 inches).

(2) Each passenger emergency exit operating handle and the cover removal instructions, if the handle is covered, must –

JAR 26.110(e)(2) (continued)

(i) Be self-illuminated with an initial brightness of at least 160 micro-lamberts (with the illumination level not decreasing in service to below 100 micro-lamberts); or

(ii) Be conspicuously located and well illuminated by the emergency lighting even in conditions of occupant crowding at the exit.

(3) Reserved

(4) All Type II and larger passenger emergency exits with a locking mechanism released by motion of a handle, must be marked by a red arrow with a shaft at least 19 mm (0.75 inch) wide, adjacent to the handle, that indicates the full extent and direction of the unlocking motion required. The word OPEN must be horizontally situated adjacent to the arrow head and must be in red capital letters at least 25 mm (1 inch) high. The arrow and word OPEN must be located on a background which provides adequate contrast. (See IEM 26.110(e)(4))

(f) Each emergency exit that is required to be openable from the outside, and its means of opening must be marked on the outside of the aeroplane. In addition, the following apply –

(1) The outside marking for each passenger emergency exit in the side of the fuselage must include one 50.80 mm (2 inch) coloured band outlining the exit.

(2) Each outside marking including the band, must have colour contrast to be readily distinguishable from the surrounding fuselage surface. The contrast must be such that if the reflectance of the darker colour is 15% or less, the reflectance of the lighter colour must be at least 45%. ‘Reflectance’ is the ratio of the luminous flux reflected by a body to the luminous flux it receives. When the reflectance of the darker colour is greater than 15%, at least a 30% difference between its reflectance and the reflectance of the lighter colour must be provided.

(3) In the case of exits other than those in the side of the fuselage, such as ventral or tail cone exits, the external means of opening, including instructions if applicable, must be conspicuously marked in red, or bright chrome yellow if the background colour is such that red is inconspicuous. When the opening is located on only one side of the fuselage, a conspicuous marking to that effect must be provided on the other side.

JAR 26.110 (continued)

(g) Each sign required by sub-paragraph (d) of this paragraph may use the word ‘exit’ in its legend in place of the term ‘emergency exit’.

## FIRE PROTECTION

### JAR 26.150 Compartment interiors (See IEM 26.150)

(Text derived from: JAR 25.853 and Appendix F at Chg. 14, 27/5/94, JAR 25.853(e) at Chg. 13 plus Amdt 91/1, 12/4/91 and JAR 25.791 at Chg. 8, 20/11/81)

For each compartment occupied by the crew or passengers the following apply –

(a) With respect to flammability, an operator shall not operate a Large Aeroplane that contains materials (including finishes applied to the materials) that do not meet the applicable test criteria prescribed in Appendix F, Part I of this JAR-26 or other approved equivalent methods, unless the aeroplane was Type Certificated against an earlier standard in which case that earlier standard applies. However, upon any major replacement of any individual group of components as specified in Appendix F, Part I, sub-paragraph (a)(1)(i), such as interior ceiling panels, wall panels, etc., this individual group of components must comply with Appendix F, Part I of this JAR-26.

(b) With respect to seat cushions, except those on flight crew member seats, an operator shall not operate a large aeroplane, Type Certificated after 1 January 1958, that does not comply with the fire protection requirements of Appendix F, Part II.

(c) (1) With respect to heat release (other than for lavatory interiors or flight deck), for interior ceiling and wall panels (other than lighting lenses), partitions, and the outer surfaces of galleys, large cabinets and stowage compartments (other than underseat stowage compartments and compartments for stowing small items, such as magazines and maps), an operator shall not operate a large aeroplane, Manufactured on or after 20 August 1988, but prior to 20 August 1990, and having a MAPSC of more than 19, that does not comply with the heat release rate testing provisions of Appendix F Part IV, except that the total heat release over the first two minutes of sample exposure must not exceed 100 kilowatt-minutes per square metre, and the peak heat release rate must not exceed 100 kilowatts per square metre.

JAR 26.150(c) (continued)

(2) With respect to heat release and smoke density, (other than for lavatory interiors or flight deck) for interior ceiling and wall panels (other than lighting lenses), partitions, and the outer surfaces of galleys, large cabinets and stowage compartments (other than underseat stowage compartments and compartments for stowing small items, such as magazines and maps), an operator shall not operate a large aeroplane, having a MAPSC of more than 19, Manufactured on or after 20 August 1990, that does not comply with the heat release and smoke density requirements of Appendix F Parts IV & V.

(3) The Authority may authorise exemption from the requirements of (c)(1) and (c)(2) of this paragraph for specific components of the cabin interior which did not meet applicable flammability and smoke emission requirements if the determination was made at the date of manufacture by the authority of the country of manufacture and accepted by the authority of the country of import, that special technical circumstances, existed that then made compliance impractical. Such exemptions shall be limited to those aeroplanes manufactured within 1 year after the applicable date specified in this paragraph and those airplanes in which an interior was replaced within 1 year of that date.

(d) An operator shall not operate a large aeroplane having a MAPSC of more than 19, Type Certificated after 1 January 1958 that, upon the first substantially complete replacement of the cabin interior components, (i.e. interior ceiling and wall panels (other than lighting lenses), partitions, and the outer surfaces of galleys, large cabinets and stowage compartments (other than underseat stowage compartments and compartments for stowing small items, such as magazines and maps)), does not comply with the heat release and smoke density requirements of Appendix F Parts IV & V.

(e) With respect to ashtrays and placards, if smoking is to be prohibited there must be a placard so stating, and if smoking is to be allowed, an operator shall not operate a large aeroplane after 1 April 2002, that does not comply with the following –

(1) There must be an adequate number of self-contained, removable ashtrays; and

(2) Where the crew compartment is separated from the passenger compartment, there must be at least one sign (using either letters or symbols) notifying when smoking is

JAR 26.150(e)(2) (continued)

prohibited. It must, when illuminated, be legible to each person seated in the passenger cabin under all probable conditions of cabin illumination, notifying all passengers when smoking is prohibited. Signs which notify when smoking is prohibited must be installed so as to be operable from either pilot's seat.

(f) With respect to disposal receptacles, an operator shall not operate a large aeroplane after 1 April 2002, that does not comply with the following –

(1) Each disposal receptacle for towels, paper or waste must be fully enclosed and constructed of materials adequate in resistance to fire such that any fire likely to occur in it under normal use will be contained. The ability of the disposal receptacle to contain those fires under all probable conditions of wear, misalignment, and ventilation expected in service must have been demonstrated by test. A placard containing the legible words or symbology indicating 'No Cigarette Disposal' must be located on or near each disposal receptacle door.

#### **JAR 26.155 Flammability of cargo compartment liners** (See IEM 26.155)

(Text derived from: JAR 25.855 & Appx F Part III, at Chg. 13 plus Amdt 93/1, dated 8 March 1993)

(a) An operator shall not operate a large aeroplane, Type Certificated after 1 January 1958, with Class C or D compartment, as defined in JAR 25.857 Amdt 93/1, 08/03/93, greater than 5.66 m<sup>3</sup> (200 cubic feet) that have ceiling and sidewall liner panels which are not constructed of : –

(1) Glass fibre reinforced resin, or

(2) Materials which meet the flame penetration test requirements of Appendix F Part III, or other approved equivalent methods, or

(3) Aluminium (only in the case of aluminium liner installations approved prior to 1 July 1989).

(b) For compliance with this section, the term 'liner' includes any design features, such as a joint or fastener which would affect the capability of the liner to safely contain a fire.

JAR 26.200(b) (continued)

**JAR 26.160 Lavatory fire protection**

(Text derived from: JAR 25.854, at Chg. 13 plus Amdt 93/1, dated 8 March 1993)

An operator shall not operate a large aeroplane with an MAPSC of more than 19 after 1 October 2000 that does not comply with the following –

(a) Each lavatory must be equipped with a smoke detector system or equivalent that provides a warning light in the cockpit, or provides a warning light or audible warning in the passenger cabin that would be readily detected by a cabin crew member; and

(b) Each lavatory must be equipped with a built-in fire extinguisher for each disposal receptacle for towels, paper, or waste, located within the lavatory. The extinguisher must be designed to discharge automatically into each disposal receptacle upon occurrence of a fire in that receptacle.

**SYSTEMS AND EQUIPMENT****JAR 26.200 Landing gear aural warning**

(Text derived from: FAR Part 121.289, Amendment 121-227)

An operator shall not operate a large aeroplane that does not comply with the following –

(a) Except for aeroplanes that comply with the requirements of JAR 25.729, effective at Amdt 93/1, dated 08/03/93, or later, each large aeroplane must have a landing gear aural warning device that functions continuously under the following conditions:

(1) For aeroplanes with an established approach flap position, whenever the flaps are extended beyond the maximum certificated approach climb configuration position in the Aeroplane Flight Manual and the landing gear is not fully extended and locked.

(2) For aeroplanes without an established approach climb flap position, whenever the flaps are extended beyond the position at which landing gear extension is normally performed and the landing gear is not fully extended and locked.

(b) The warning system required by subparagraph (a) of this paragraph –

(1) May not have a manual shut-off means readily available to the flight crew such that it could be operated instinctively, inadvertently or by habitual reflexive action;

(2) Must be in addition to the throttle-actuated device installed under the airworthiness type certification requirements; and

(3) May utilise any part of the throttle-actuated system including the aural warning device.

(c) The flap position sensing unit may be installed at any suitable place in the aeroplane.

**[ JAR 26.260 Security Considerations**

(See ACJ 26.260)

The applicability, as defined here-after, may be affected by and be changed in accordance with national security programmes addressing onboard security.

From 1 November 2003, all passenger carrying aeroplanes of a maximum certificated take-off mass in excess of 45 500 kg or with a passenger seating capacity greater than 60, and having a lockable door installed between the pilot compartment and the passenger compartment, shall meet the following requirements :

(a) Protection of flight deck. If a flight deck door is required by operating rules, the door installation must be designed to:

(1) Resist forcible intrusion by unauthorized persons and be capable of withstanding impacts of 300 Joules (221.3 foot-pounds) at the critical locations on the door, as well as a 1 113 Newton (250 pound) constant tensile load on the knob or handle (See ACJ 26.260(a)(1)), and

(2) Resist penetration by small arms fire and fragmentation devices by meeting the following projectile definitions and projectile speeds (See ACJ 26.260(a)(2)).

(i) Demonstration Projectile #1.  
A 9 mm full metal jacket, round nose (FMJ RN) bullet with nominal mass of 8.0 g (124 grain) and reference velocity 436 m/s (1 430 ft/s)

(ii) Demonstration Projectile #2.  
A .44 Magnum, jacketed hollow point (JHP) bullet with nominal mass of 15.6 g (240 grain) and reference velocity 436 m/s (1 430 ft/s)]

[Amdt. 1, 01.05.03]

## Appendix F

## Part I — Test Criteria and Procedures for Showing Compliance with JAR 25.853, or 25.855.

Text derived from JAR-25 Appx F, Part I at Chg 14, plus Amendment 93/1, dated 08/03/93

(a) *Material test criteria*(1) *Interior compartments occupied by crew or passengers.*

(i) Interior ceiling panels, interior wall panels, partitions, galley structure, large cabinet walls, structural flooring, and materials used in the construction of stowage compartments (other than underseat stowage compartments and compartments for stowing small items such as magazines and maps) must be self-extinguishing when tested vertically in accordance with the applicable portions of Part I of this Appendix. The average burn length may not exceed 152.40 mm (6 inches) and the average flame time after removal of the flame source may not exceed 15 seconds. Drippings from the test specimen may not continue to flame for more than an average of 3 seconds after falling.

(ii) Floor covering, textiles (including draperies and upholstery), seat cushions, padding, decorative and non-decorative coated fabrics, leather, trays and galley furnishings, electrical conduit, thermal and acoustical insulation and insulation covering, air ducting, joint and edge covering, liners of Class B and E cargo or baggage compartments, floor panels of Class B, C, D, or E cargo or baggage compartments, insulation blankets, cargo covers and transparencies, moulded and thermoformed parts, air ducting joints, and trim strips (decorative and chafing), that are constructed of materials not covered in sub-paragraph (iv) below, must be self-extinguishing when tested vertically in accordance with the applicable portions of Part I of this Appendix or other approved equivalent means. The average burn length may not exceed 203.2 mm (8 inches), and the average flame time after removal of the flame source may not exceed 15 seconds. Drippings from the test specimen may not continue to flame for more than an average of 5 seconds after falling.

(iii) Motion picture film must be safety film meeting the Standard Specifications for Safety Photographic Film PH1.25 (available from the American National Standards Institute, 1430 Broadway, New York, NY 10018). If the film travels through ducts, the ducts must meet the requirements of sub-paragraph (ii) of this paragraph.

(iv) Clear plastic windows and signs, parts constructed in whole or in part of elastomeric materials, edge lighted instrument assemblies consisting of two or more instruments in a common housing, seat belts, shoulder harnesses, and cargo and baggage tiedown equipment, including containers, bins, pallets, etc, used in passenger or crew compartments, may not have an average burn rate greater than 63.5 mm (2.5 inches) per minute when tested horizontally in accordance with the applicable portions of this Appendix.

(v) Except for small parts (such as knobs, handles, rollers, fasteners, clips, grommets, rub strips, pulleys, and small electrical parts) that would not contribute significantly to the propagation of a fire and for electrical wire and cable insulation, materials in items not specified in paragraphs (a)(1)(i),(ii),(iii), or (iv) of Part I of this Appendix may not have a burn rate greater than 101.6 mm (4 inches) per minute when tested horizontally in accordance with the applicable portions of this Appendix.

(2) *Cargo and baggage compartments not occupied by crew or passengers.*

(i) Thermal and acoustic insulation (including coverings) used in each cargo and baggage compartment must be constructed of materials that meet the requirements set forth in sub-paragraph (a)(1)(ii) of Part I of this Appendix.

(ii) A cargo or baggage compartment defined in JAR 25.857 as Class B or E must have a liner constructed of materials that meet the requirements of sub-paragraph (a)(1)(ii) of Part I of this Appendix and separated

## Appendix F (Part I) (continued)

from the aeroplane structure (except for attachments). In addition, such liners must be subjected to the 45 degree angle test as specified in sub-paragraph (b) (6) of Part I of this Appendix. The flame may not penetrate (pass through) the material during application of the flame or subsequent to its removal. The average flame time after removal of the flame source may not exceed 15 seconds, and the average glow time may not exceed 10 seconds.

(iii) A cargo or baggage compartment defined in JAR 25.857 as Class B, C, D, or E must have floor panels constructed of materials which meet the requirements of sub-paragraph (a)(1)(ii) of Part I of this Appendix and which are separated from the aeroplane structure (except for attachments). Such panels must be subjected to the 45 degree angle test as specified in sub-paragraph (b) (6) of Part I of this Appendix. The flame may not penetrate (pass through) the material during application of the flame or subsequent to its removal. The average flame time after removal of the flame source may not exceed 15 seconds, and the average glow time may not exceed 10 seconds.

(iv) Insulation blankets and covers used to protect cargo must be constructed of materials that meet the requirements of sub-paragraph (a)(1)(ii) of Part I of this Appendix. Tie-down equipment (including containers, bins, and pallets) used in each cargo and baggage compartment must be constructed of materials that meet the requirements of sub-paragraph (a)(1)(v) of Part I of this Appendix.

(3) *Electrical system components.* Insulation on electrical wire or cable installed in any area of the fuselage must be self-extinguishing when subjected to the 60 degree test as specified in sub-paragraph (b) (7) of Part I of this Appendix. The average burn length may not exceed 76.2 mm (3 inches) and the average flame time after removal of the flame source may not exceed 30 seconds. Drippings from the test specimen may not continue to flame for more than an average of 3 seconds after falling.

(b) *Test Procedures –*

(1) *Conditioning.* Specimens must be conditioned to  $70 \pm 5^\circ\text{F}$  ( $21.11 \pm 3^\circ\text{C}$ ), and at  $50\% \pm 5\%$  relative humidity until moisture equilibrium is reached or for 24 hours. Each specimen must remain in the conditioning environment until it is subjected to the flame.

(2) *Specimen configuration.* Except for small parts and electrical wire and cable insulation, materials must be tested either as a section cut from a fabricated part as installed in the aeroplane or as a specimen simulating a cut section, such as a specimen cut from a flat sheet of the material or a model of the fabricated part. The specimen may be cut from any location in a fabricated part; however, fabricated units, such as sandwich panels, may not be separated for test. Except as noted below, the specimen thickness must be no thicker than the minimum thickness to be qualified for use in the aeroplane. Test specimens of thick foam parts, such as seat cushions, must be 12.7 mm ( $\frac{1}{2}$ -inch) in thickness. Test specimens of materials that must meet the requirements of sub-paragraph (a)(1)(v) of Part I of this Appendix must be no more than 3.175 mm ( $\frac{1}{8}$ -inch) in thickness. Electrical wire and cable specimens must be the same size as used in the aeroplane. In the case of fabrics, both the warp and fill direction of the weave must be tested to determine the most critical flammability condition. Specimens must be mounted in a metal frame so that the two long edges and the upper edge are held securely during the vertical test prescribed in sub-paragraph (4) of this paragraph and the two long edges and the edge away from the flame are held securely during the horizontal test prescribed in sub-paragraph (5) of this paragraph. The exposed area of the specimen must be at least 50.8 mm (2 inches) wide and 304.8 mm (12 inches) long, unless the actual size used in the aeroplane is smaller. The edge to which the burner flame is applied must not consist of the finished or protected edge of the specimen but must be representative of the actual cross-section of the material or part as installed in the aeroplane. The specimen must be mounted in a metal frame so that all four edges are held securely and the exposed area of the specimen is at least 203.2 mm by 203.2 mm (8 inches by 8 inches) during the 45° test prescribed in sub-paragraph (6) of this paragraph.

## Appendix F (Part I) (continued)

(3) *Apparatus.* Except as provided in sub-paragraph (7) of this paragraph, tests must be conducted in a draught-free cabinet in accordance with Federal Test Method Standard 191 Model 5903 (revised Method 5902) for the vertical test, or Method 5906 for horizontal test (available from the General Services Administration, Business Service Centre, Region 3, Seventh & D Streets SW., Washington, DC 20407, USA). Specimens which are too large for the cabinet must be tested in similar draught-free conditions.

(4) *Vertical test.* A minimum of three specimens must be tested and results averaged. For fabrics, the direction of weave corresponding to the most critical flammability conditions must be parallel to the longest dimension. Each specimen must be supported vertically. The specimen must be exposed to a Bunsen or Tirrill burner with a nominal 9.525 mm ( $\frac{3}{8}$ -inch) I.D. tube adjusted to give a flame of 38.1 mm ( $1\frac{1}{2}$  inches) in height. The minimum flame temperature measured by a calibrated thermocouple pyrometer in the centre of the flame must be 843.33 °C (1550 °F). The lower edge of the specimen must be 19.05 mm ( $\frac{3}{4}$ -inch) above the top edge of the burner. The flame must be applied to the centre line of the lower edge of the specimen. For materials covered by sub-paragraph (a)(1)(i) of Part I of this Appendix, the flame must be applied for 60 seconds and then removed. For materials covered by sub-paragraph (a)(1)(ii) of Part I of this Appendix, the flame must be applied for 12 seconds and then removed. Flame time, burn length, and flaming time of drippings, if any, may be recorded. The burn length determined in accordance with sub-paragraph (7) of this paragraph must be measured to the nearest 2.54 mm (tenth of an inch).

(5) *Horizontal test.* A minimum of three specimens must be tested and the results averaged. Each specimen must be supported horizontally. The exposed surface, when installed in the aircraft, must be face down for the test. The specimen must be exposed to a Bunsen or Tirrill burner with a nominal 9.525 mm ( $\frac{3}{8}$ -inch) I.D. tube adjusted to give a flame of 38.1 mm ( $1\frac{1}{2}$  inches) in height. The minimum flame temperature measured by a calibrated thermocouple pyrometer in the centre of the flame must be 843.33°C (1550°F). The specimen must be positioned

so that the edge being tested is centred 19.05 mm ( $\frac{3}{4}$ -inch) above the top of the burner. The flame must be applied for 15 seconds and then removed. A minimum of 254 mm (10 inches) of specimen must be used for timing purposes, approximately 38.1 mm ( $1\frac{1}{2}$  inches) must burn before the burning front reaches the timing zone, and the average burn rate must be recorded.

(6) *Forty-five degree test.* A minimum of three specimens must be tested and the results averaged. The specimens must be supported at an angle of 45° to a horizontal surface. The exposed surface when installed in the aircraft must be face down for the test. The specimens must be exposed to a Bunsen or Tirrill burner with a nominal 9.525 mm ( $\frac{3}{8}$ -inch) I.D. tube adjusted to give a flame of 38.1 mm ( $1\frac{1}{2}$  inches) in height. The minimum flame temperature measured by a calibrated thermocouple pyrometer in the centre of the flame must be 843.33°C (1550°F). Suitable precautions must be taken to avoid draughts. The flame must be applied for 30 seconds with one-third contacting the material at the centre of the specimen and then removed. Flame time, glow time, and whether the flame penetrates (passes through) the specimen must be recorded.

(7) *Sixty degree test.* A minimum of three specimens of each wire specification (make and size) must be tested. The specimen of wire or cable (including insulation) must be placed at an angle of 60° with the horizontal in the cabinet specified in sub-paragraph (3) of this paragraph with the cabinet door open during the test, or must be placed within a chamber approximately 609.6 mm (2 feet) high by 304.8 mm by 304.8 mm (1 foot by 1 foot), open at the top and at one vertical side (front), and which allows sufficient flow of air for complete combustion, but which is free from draughts. The specimen must be parallel to and approximately 152.4 mm (6 inches) from the front of the chamber. The lower end of the specimen must be held rigidly clamped. The upper end of the specimen must pass over a pulley or rod and must have an appropriate weight attached to it so that the specimen is held tautly throughout the flammability test. The test specimen span between lower clamp and upper pulley or rod must be 609.6 mm (24 inches) and must be marked 203.2 mm (8 inches) from the lower end to indicate the

## Appendix F (Part I) (continued)

central point for flame application. A flame from a Bunsen or Tirrill burner must be applied for 30 seconds at the test mark. The burner must be mounted underneath the test mark on the specimen, perpendicular to the specimen and at an angle of 30° to the vertical plane of the specimen. The burner must have a nominal bore of 9.525 mm (<sup>3</sup>/<sub>8</sub>-inch) and be adjusted to provide a 76.2 mm (3-inch) high flame with an inner cone approximately one-third of the flame height. The minimum temperature of the hottest portion of the flame, as measured with a calibrated thermocouple pyrometer, may not be less than 954.44°C (1750°F). The burner must be positioned so that the hottest portion of the flame is applied to the test mark on the wire. Flame time, burn length, and flaming time of drippings, if any, must be recorded. The burn length determined in accordance with sub-paragraph (8) of this paragraph must be measured to the nearest 2.54 mm (tenth of an inch). Breaking of the wire specimens is not considered a failure.

(8) *Burn length.* Burn length is the distance from the original edge to the farthest evidence of damage to the test specimen due to flame impingement, including areas of partial or complete consumption, charring, or embrittlement, but not including areas sooted, stained, warped, or discoloured, nor areas where material has shrunk or melted away from the heat source.

INTENTIONALLY LEFT BLANK

**Appendix F (continued)**  
**Part II — Flammability of Seat Cushions**

Text derived from: JAR-25 Appendix F, Part II at Chg 12, plus Amendment 86/1, 16/6/86, and reissued by  
Chg 13 15/10/89

(a) *Criteria for Acceptance.* Each seat cushion must meet the following criteria:

(1) At least three sets of seat bottom and seat back cushion specimens must be tested.

(2) If the cushion is constructed with a fire blocking material, the fire blocking material must completely enclose the cushion foam core material.

(3) Each specimen tested must be fabricated using the principal components (i.e. foam core, flotation material, fire blocking material, if used, and dress covering) and assembly processes (representative seams and closures) intended for use in the production articles. If a different material combination is used for the back cushion than for the bottom cushion, both material combinations must be tested as complete specimen sets, each set consisting of a back cushion specimen and a bottom cushion specimen. If a cushion, including outer dress covering, is demonstrated to meet the requirements of this Appendix using the oil burner test, the dress covering of that cushion may be replaced with a similar dress covering provided the burn length of the replacement covering, as determined by the test specified in JAR 25.853(b), does not exceed the corresponding burn length of the dress covering used on the cushion subjected to the oil burner test.

(4) For at least two-thirds of the total number of specimen sets tested, the burn length from the burner must not reach the side of the cushion opposite the burner. The burn length must not exceed 431.8 mm (17 inches). Burn length is the perpendicular distance from the inside edge of the seat frame closest to the burner to the farthest evidence of damage to the test specimen due to flame impingement, including areas of partial or complete consumption, charring, or embrittlement, but not including areas sooted, stained, warped, or discoloured, or areas where material has shrunk or melted away from the heat source.

(5) The average percentage weight loss must not exceed 10 percent. Also, at least two-thirds of the total number of specimen sets tested must not exceed 10 percent weight

loss. All droppings falling from the cushions and mounting stand are to be discarded before the after-test weight is determined. The percentage weight loss for a specimen set is the weight of the specimen set before testing less the weight of the specimen set after testing expressed as the percentage of the weight before testing.

(b) *Test Conditions.* Vertical air velocity should average  $0.127 \text{ m/s} \pm 0.05 \text{ m/s}$  (25 fpm  $\pm 10$  fpm) at the top of the back seat cushion. Horizontal air velocity should be below  $0.05 \text{ m/s}$  (10 fpm) just above the bottom seat cushion. Air velocities should be measured with the ventilation hood operating and the burner motor off.

(c) *Test Specimens*

(1) For each test, one set of cushion specimens representing a seat bottom and seat back cushion must be used.

(2) The seat bottom cushion specimen must be  $457 \pm 3 \text{ mm}$  ( $18 \pm 0.125$  inches) wide by  $508 \pm 3 \text{ mm}$  ( $20 \pm 0.125$  inches) deep by  $102 \pm 3 \text{ mm}$  ( $4 \pm 0.125$  inches) thick, exclusive of fabric closures and seam overlap.

(3) The seat back cushion specimen must be  $432 \pm 3 \text{ mm}$  ( $18 \pm 0.125$  inches) wide by  $635 \pm 3 \text{ mm}$  ( $25 \pm 0.125$  inches) high by  $51 \pm 3 \text{ mm}$  ( $2 \pm 0.125$  inches) thick, exclusive of fabric closures and seam overlap.

(4) The specimens must be conditioned at  $21 \pm 2^\circ\text{C}$  ( $70 \pm 5^\circ\text{F}$ ) 55%  $\pm 10\%$  relative humidity for at least 24 hours before testing.

(d) *Test Apparatus.* The arrangement of the test apparatus is shown in Figure 1 through 5 and must include the components described in this paragraph. Minor details of the apparatus may vary, depending on the model burner used.

(1) *Specimen Mounting Stand.* The mounting stand for the test specimens consist of steel angles, as shown in Figure 1. The length of the mounting stand legs is  $305 \pm 3 \text{ mm}$  ( $12 \pm 0.125$  inches). The mounting stand must be used for mounting the test specimen seat bottom and seat back, as shown in Figure 2. The mounting stand should also include a suitable drip pan lined with aluminium foil, dull side up.

## Appendix F (Part II) (continued)

(2) *Test Burner.* The burner to be used in testing must –

- (i) Be a modified gun type;
- (ii) Have an 80-degree spray angle nozzle nominally rated for 2.25 US gallons/hour at 100 psi;
- (iii) Have a 305 mm (12-inch) burner cone installed at the end of the draft tube, with an opening 152 mm (6 inches) high and 208 mm (11 inches) wide, as shown in Figure 3; and
- (iv) Have a burner fuel pressure regulator that is adjusted to deliver a nominal 2.0 US gallon/hour of # 2 Grade kerosene or equivalent required for the test.

(3) *Calorimeter*

(i) The calorimeter to be used in testing must be a 0–17.0 Watts/cm<sup>2</sup> (0–15.0 BTU per ft<sup>2</sup> sec) calorimeter, accurate ± 3%, mounted in a 152 by 305 mm (6 inch by 12 inch) by 19 mm (0.75 inch) thick calcium silicate insulating board which is attached to a steel angle bracket for placement in the test stand during burner calibration, as shown in Figure 4.

(ii) Because crumbling of the insulating board with service can result in misalignment of the calorimeter, the calorimeter must be monitored and the mounting shimmed, as necessary, to ensure that the calorimeter face is flush with the exposed plane of the insulating board in a plane parallel to the exit of the test burner cone.

(4) *Thermocouples.* The seven thermo-couples to be used for testing must be 0.0625 to 0.125 inch metal sheathed, ceramic packed, type K, grounded thermocouples with a nominal 22 to 30 American wire gauge (AWG)-size conductor (0.643 mm (0.0253 inches) to 0.254 mm (0.010 inches) diameter). The seven thermocouples must be attached to a steel angle bracket to form a thermocouple rake for placement in the test stand during burner calibration as shown in Figure 5.

(5) *Apparatus Arrangement.* The test burner must be mounted on a suitable stand to position the exit of the burner cone a distance of 102 ± 3 mm (4 ± 0.125 inches) from one side of the specimen mounting stand. The

burner stand should have the capability of allowing the burner to be swung from the specimen mounting stand during warmup periods.

(6) *Data Recording.* A recording potentiometer or other suitable calibrated instrument with an appropriate range must be used to measure and record the outputs of the calorimeter and the thermocouples.

(7) *Weight Scale. Weighing Device –* A device must be used that with proper procedures may determine the before and after test weights of each set of seat cushion specimens within 9 grams (0.02 pound). A continuous weighing system is preferred.

(8) *Timing Device.* A stopwatch or other device (calibrated to ± 1 second) must be used to measure the time of application of the burner flame and self-extinguishing time or test duration.

(e) *Preparation of Apparatus.* Before calibration, all equipment must be turned on and the burner fuel must be adjusted as specified in sub-paragraph (d)(2).

(f) *Calibration.* To ensure the proper thermal output of the burner, the following test must be made:

(1) Place the calorimeter on the test stand as shown in Figure 4 at a distance of 102 ± 3 mm (4 ± 0.125 inches) from the exit of the burner cone.

(2) Turn on the burner, allow it to run for 2 minutes for warmup, and adjust the burner air intake damper to produce a reading of 11.9 ± 0.6 Watts/cm<sup>2</sup> (10.5 ± 0.5 BTU per ft<sup>2</sup> sec) on the calorimeter to ensure steady state conditions have been achieved. Turn off the burner.

(3) Replace the calorimeter with the thermocouple rake (Figure 5).

(4) Turn on the burner and ensure that the thermocouples are reading 1038 ± 38°C (1900 ± 100°F) to ensure steady state conditions have been achieved.

(5) If the calorimeter and thermocouples do not read within range, repeat steps in sub-paragraphs 1 to 4 and adjust the burner air intake damper until the proper readings are obtained. The thermocouple rake and the calorimeter should be used frequently to maintain and record

## Appendix F (Part II) (continued)

calibrated test parameters. Until the specific apparatus has demonstrated consistency, each test should be calibrated. After consistency has been confirmed, several tests may be conducted with the pre-test calibration before and a calibration check after the series.

(g) *Test Procedures.* The flammability of each set of specimens must be tested as follows:

(1) Record the weight of each set of seat bottom and seat back cushion specimens to be tested to the nearest 9 grams (0.02 pound).

(2) Mount the seat bottom and seat back cushion test specimens on the test stand as shown in Figure 2, securing the seat back cushion specimen to the test stand at the top.

(3) Swing the burner into position and ensure that the distance from the exit of the burner cone to the side of the seat bottom cushion specimen is  $102 \pm 3$  mm ( $4 \pm 0.125$  inches).

(4) Swing the burner away from the test position. Turn on the burner and allow it to run for 2 minutes to provide adequate warmup of the burner cone and flame stabilization.

(5) To begin the test, swing the burner into the test position and simultaneously start the timing device.

(6) Expose the seat bottom cushion specimen to the burner for 2 minutes and then turn off the burner. Immediately swing the burner away from the test position. Terminate test 7 minutes after initiating cushion exposure to the flame by use of a gaseous extinguishing agent (i.e. Halon or CO<sub>2</sub>).

(7) Determine the weight of the remains of the seat cushion specimen set left

on the mounting stand to the nearest 9 grams (0.02 pound) excluding all droppings.

(h) *Test Report.* With respect to all specimen sets tested for a particular seat cushion for which testing of compliance is performed, the following information must be recorded:

(1) An identification and description of the specimens being tested.

(2) The number of specimen sets tested.

(3) The initial weight and residual weight of each set, the calculated percentage weight loss of each set, and the calculated average percentage weight loss for the total number of sets tested.

(4) The burn length for each set tested.

INTENTIONALLY LEFT BLANK

Appendix F (Part II) (continued)

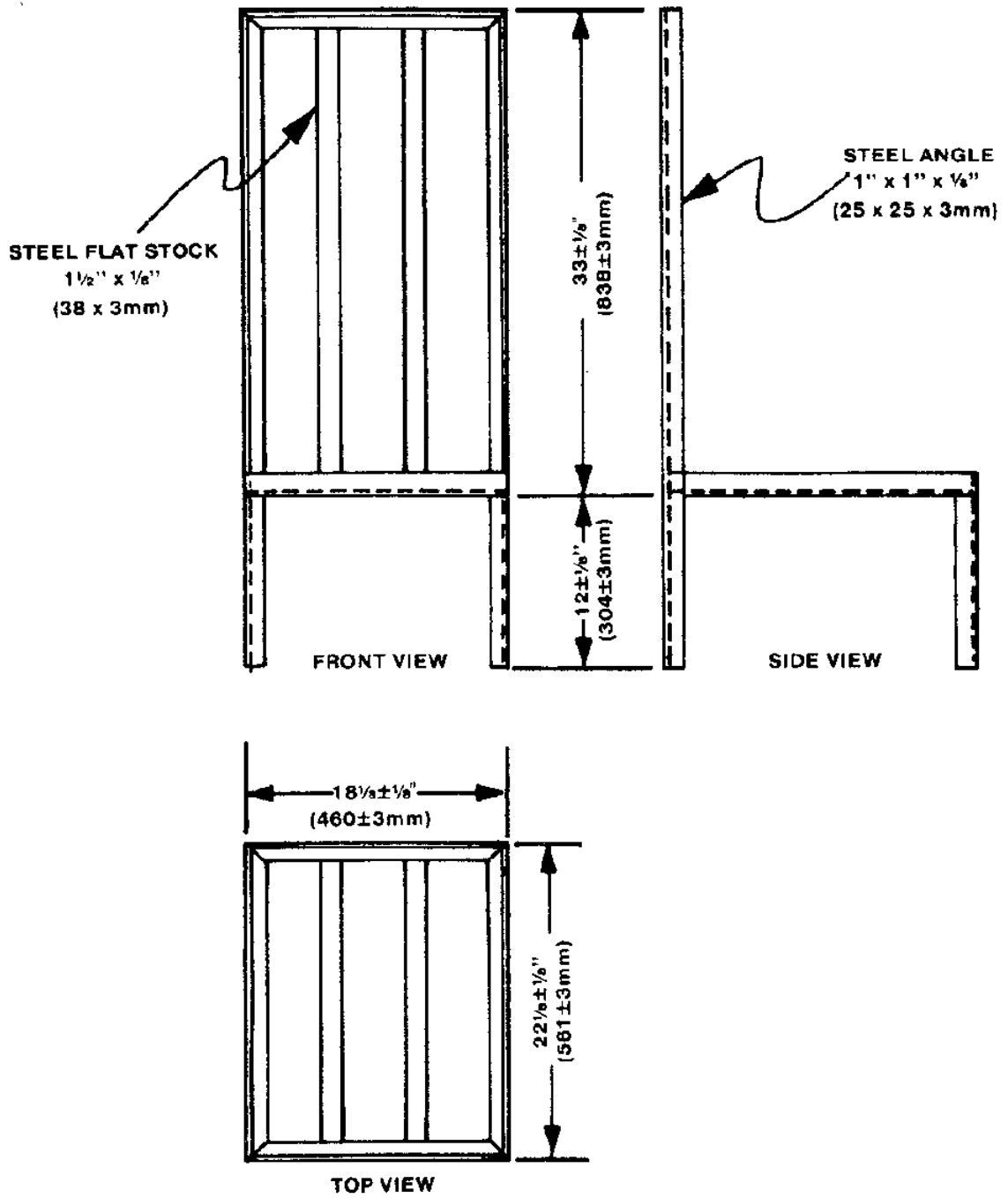

FIGURE 1

Appendix F (Part II) (continued)

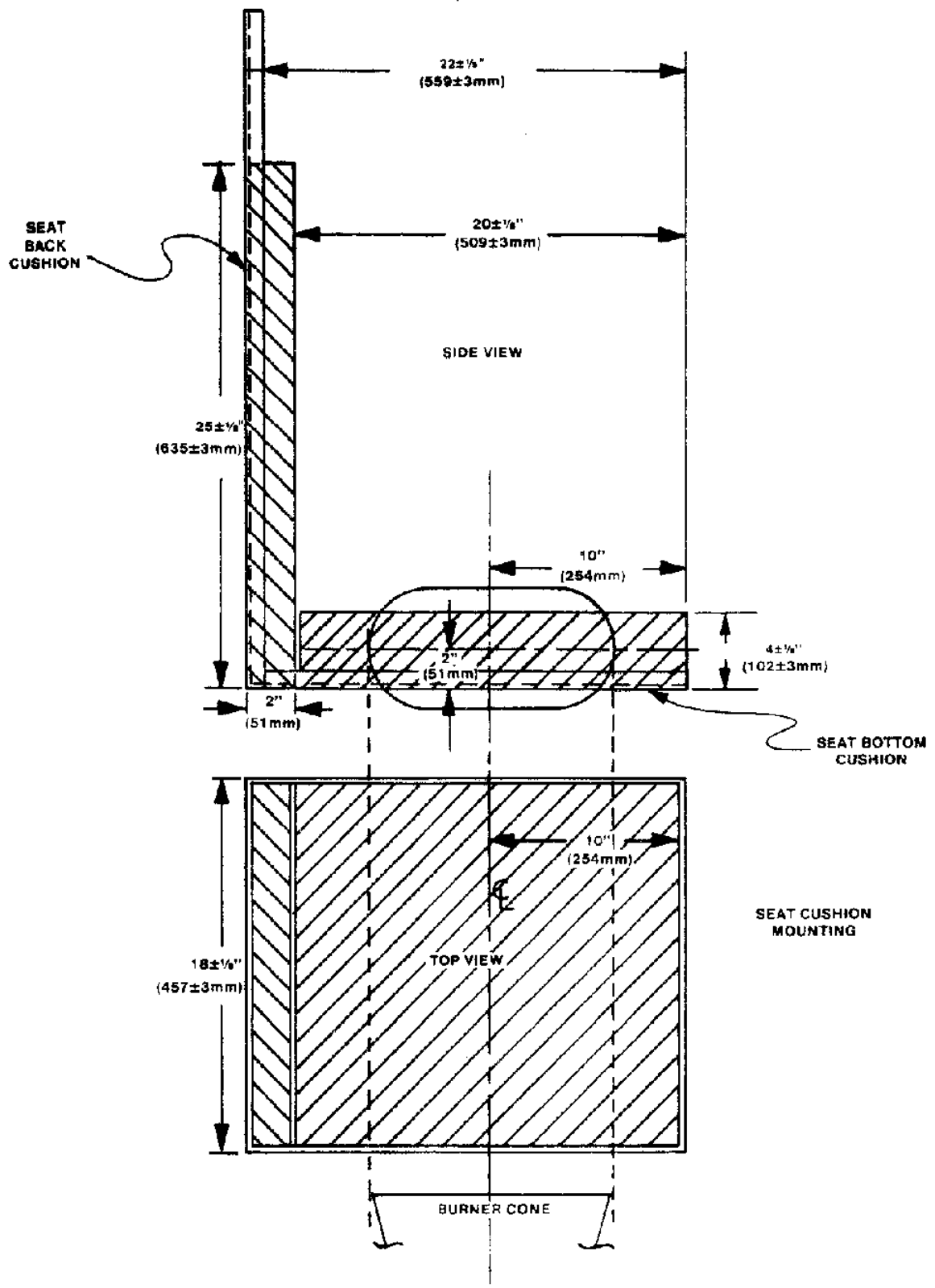

FIGURE 2

Appendix F (Part II) (continued)

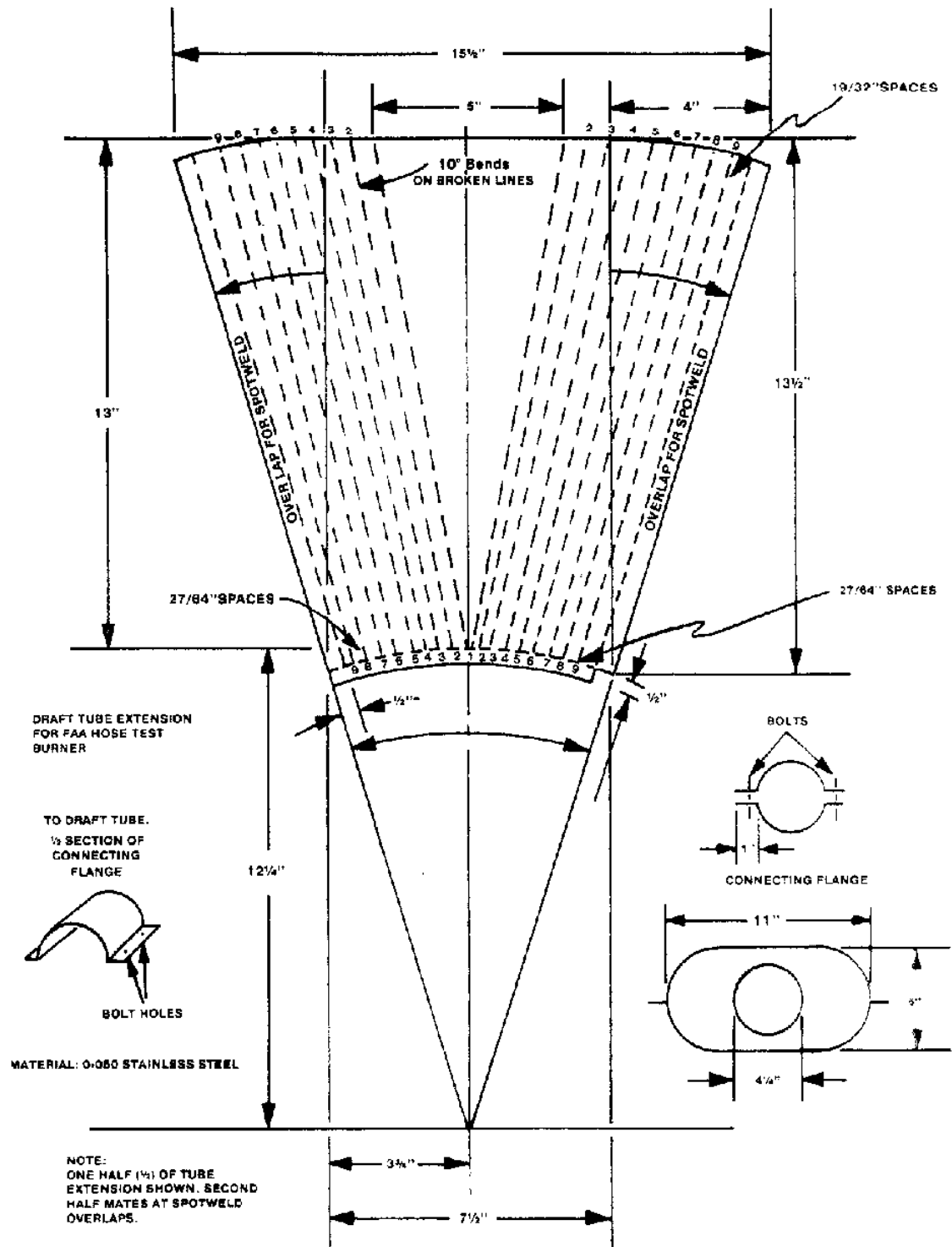

FIGURE 3

Appendix F (Part II) (continued)

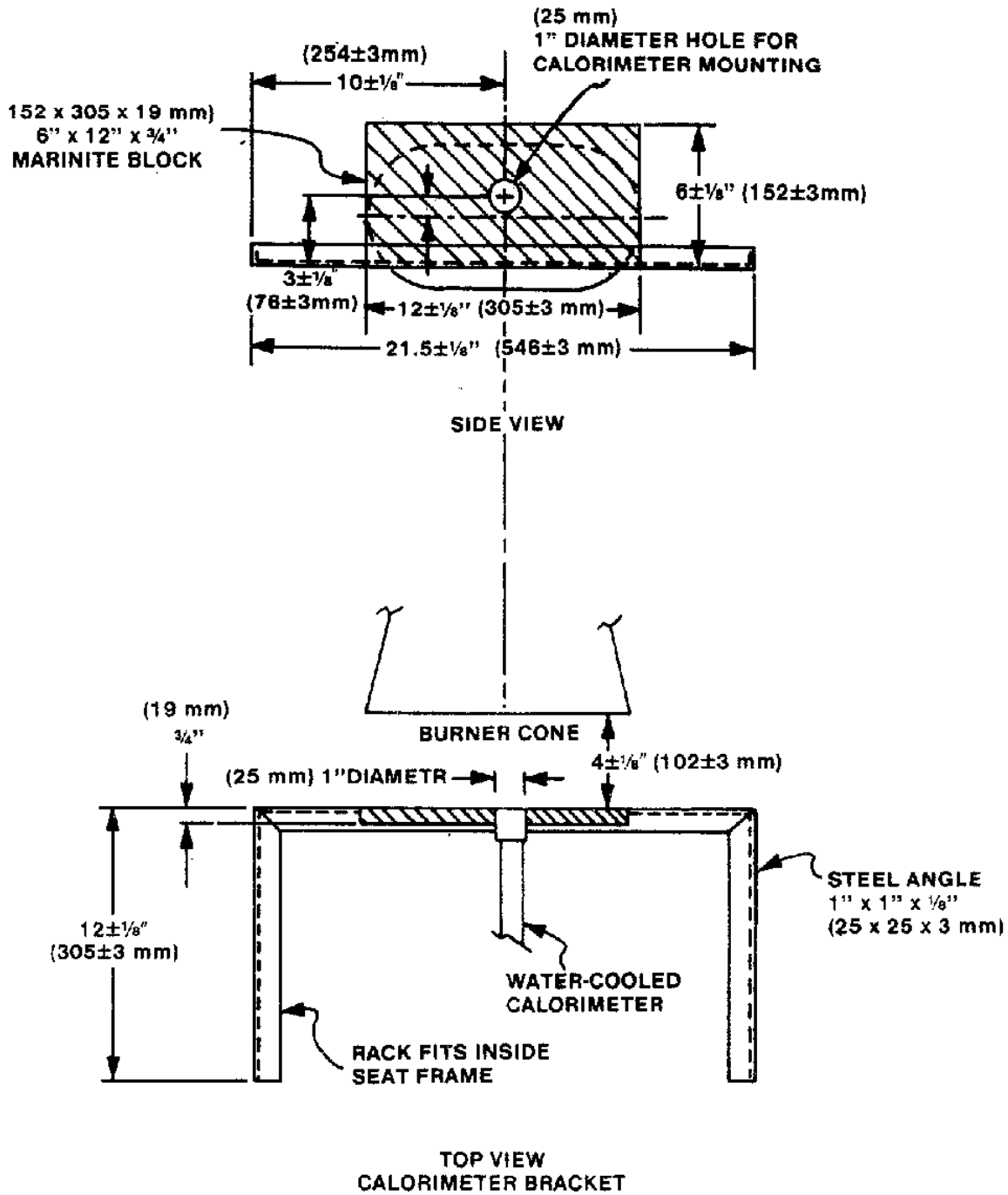

FIGURE 4

Appendix F (Part II) (continued)

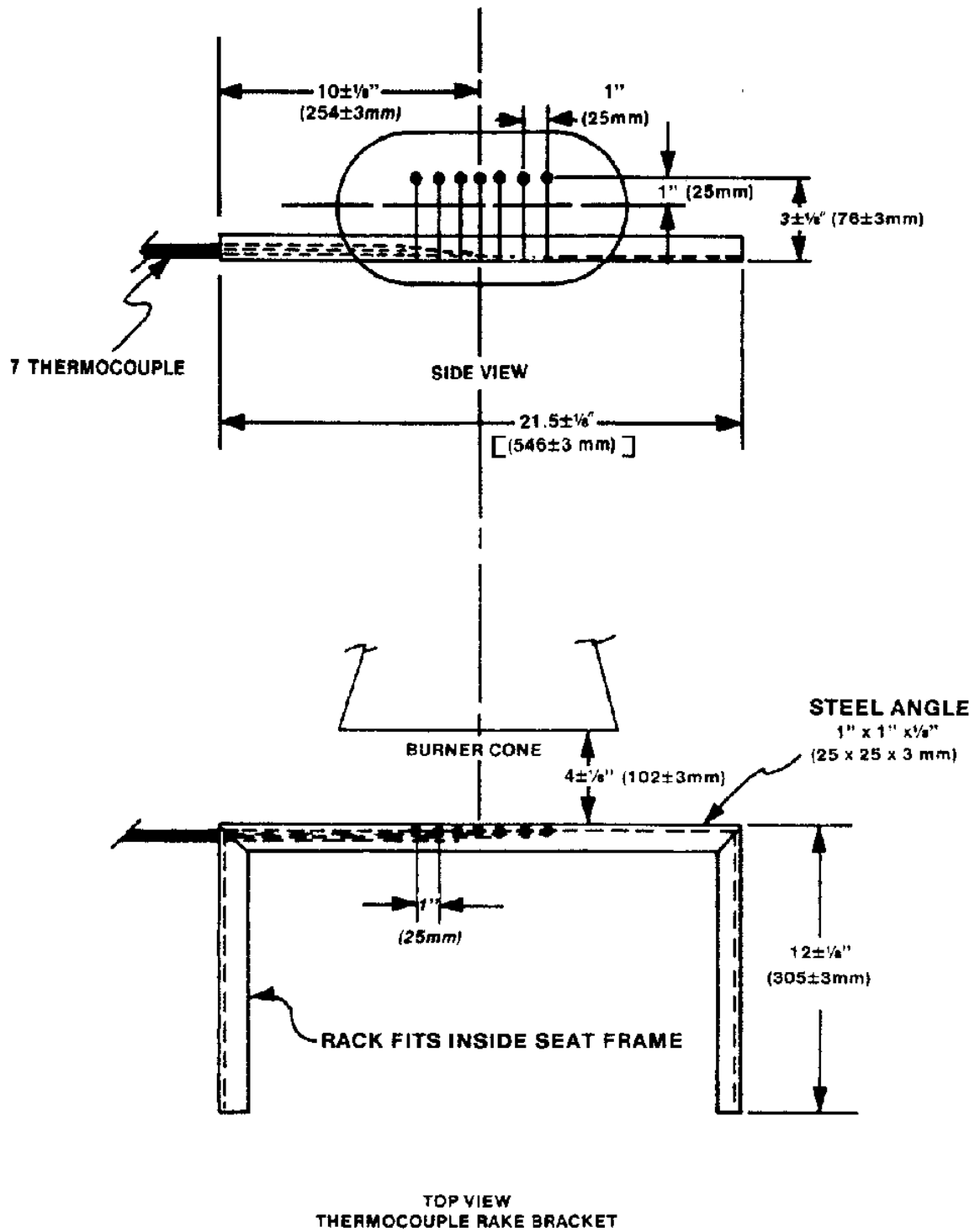

FIGURE 5

## Appendix F (continued)

## Part III – Test Method to Determine Flame Penetration Resistance of Cargo Compartment Liners

Text derived from: JAR-25 Appendix F, Part III at Chg 12, plus Amdt 86/2 5/10.86, and reissued by Chg 13

(a) *Criteria for Acceptance*

(1) At least three specimens of cargo compartment sidewall or ceiling liner panels must be tested.

(2) Each specimen tested must simulate the cargo compartment sidewall or ceiling liner panel, including any design features, such as joints, lamp assemblies, etc., the failure of which would affect the capability of the liner to safely contain a fire.

(3) There must be no flame penetration of any specimen within 5 minutes after application of the flame source, and the peak temperature measured at 4 inches above the upper surface of the horizontal test sample must not exceed 222-22°C (400°F).

(b) *Summary of Method.* This method provides a laboratory test procedure for measuring the capability of cargo compartment lining materials to resist flame penetration within a 2 US gallons/hour # 2 Grade kerosene or equivalent burner fire source. Ceiling and sidewall liner panels may be tested individually provided a baffle is used to simulate the missing panel. Any specimen that passes the test as a ceiling liner panel may be used as a sidewall liner panel.

(c) *Test Specimens*

(1) The specimen to be tested must measure 406 ± 3 mm (16 ± 0.125 inches) by 610 ± 3 mm (24 ± 0.125 inches).

(2) The specimens must be conditioned at 21°C ± 2°C (70°F ± 5°F) and 55% ± 5% humidity for at least 24 hours before testing.

(d) *Test Apparatus.* The arrangement of the test apparatus, which is shown in Figure 3 of Part II and Figures 1 through 3 of this Part of Appendix F, must include the components described in this paragraph. Minor details of the apparatus may vary, depending on the model of the burner used.

(1) *Specimen Mounting Stand.* The mounting stand for the test specimens consists of steel angles as shown in Figure 1.

(2) *Test Burner.* The burner to be used in testing must –

(i) Be a modified gun type.

(ii) Use a suitable nozzle and maintain fuel pressure to yield a 2 US gallons/hour fuel flow. For example: an 80 degree nozzle nominally rated at 2.25 US gallons/hour and operated at 85 pounds per square inch (PSI) gauge to deliver 2.03 US gallons/hour.

(iii) Have a 305 mm (12 inch) burner extension installed at the end of the draft tube with an opening 152 mm (6 inches) high and 280 mm (11 inches) wide as shown in Figure 3 of Part II of this Appendix.

(iv) Have a burner fuel pressure regulator that is adjusted to deliver a nominal 2.0 US gallons/hour of # 2 Grade kerosene or equivalent.

(3) *Calorimeter*

(i) The calorimeter to be used in testing must be a total heat flux Foil Type Gardon Gauge of an appropriate range, approximately 0–17.0 Watts/cm<sup>2</sup> (0 to 15.0 BTU per ft<sup>2</sup> sec). The calorimeter must be mounted in a 152 by 305 mm (6 inch by 12 inch) by 19 mm (0.75 inch) thick insulating block which is attached to a steel angle bracket for placement in the test stand during burner calibration as shown in Figure 2 of this Part of this Appendix.

(ii) The insulating block must be monitored for deterioration and the mounting shimmed as necessary to ensure that the calorimeter face is parallel to the exit plane of the test burner cone.

(4) *Thermocouples.* The seven thermocouples to be used for testing must be 0.0625 of an inch ceramic sheathed, type K, grounded thermocouples with a nominal 30 American wire gauge (AWG)-size conductor (0.254 mm (0.010 inches) diameter). The seven thermocouples must be attached to a steel angle bracket to form a thermocouple rake for placement in the stand during burner calibration as shown in Figure 3 of this Part of this Appendix.

(5) *Apparatus Arrangement.* The test burner must be mounted on a suitable stand to position the exit of the burner cone a distance of 203.2 mm (8 inches) from the ceiling liner

## Appendix F (Part III) (continued)

panel and 50.8 mm (2 inches) from the sidewall liner panel. The burner stand should have the capability of allowing the burner to be swung away from the test specimen during warm-up periods.

(6) *Instrumentation.* A recording potentiometer or other suitable instrument with an appropriate range must be used to measure and record the outputs of the calorimeter and the thermocouples.

(7) *Timing Device.* A stopwatch or other device must be used to measure the time of flame application and the time of flame penetration, if it occurs.

(e) *Preparation of Apparatus.* Before calibration, all equipment must be turned on and allowed to stabilize, and the burner fuel flow must be adjusted as specified in sub-paragraph (d)(2).

(f) *Calibration.* To ensure the proper thermal output of the burner the following test must be made:

(1) Remove the burner extension from the end of the draft tube. Turn on the blower portion of the burner without turning the fuel or igniters on. Measure the air velocity using a hot wire anemometer in the centre of the draft tube across the face of the opening. Adjust the damper such that the air velocity is in the range of 7.97 to 9.14 m/s (1550 to 1800 fpm). If tabs are being used at the exit of the draft tube, they must be removed prior to this measurement. Reinstall the draft tube extension cone.

(2) Place the calorimeter on the test stand as shown in Figure 2 at a distance of 203 mm (8 inches) from the exit of the burner cone to simulate the position of the horizontal test specimen.

(3) Turn on the burner, allow it to run for 2 minutes for warm-up, and adjust the damper to produce a calorimeter reading of  $9.1 \pm 0.6$  Watts/cm<sup>2</sup> ( $8.0 \pm 0.5$  BTU per ft<sup>2</sup> sec).

(4) Replace the calorimeter with the thermocouple rake (see Figure 3).

(5) Turn on the burner and ensure that each of the seven thermocouples reads  $927^{\circ}\text{C} \pm 38^{\circ}\text{C}$  ( $1700^{\circ}\text{F} \pm 100^{\circ}\text{F}$ ) to ensure steady state conditions have been achieved. If the temperature is out of this range, repeat steps 2 through 5 until proper readings are obtained.

(6) Turn off the burner and remove the thermocouple rake.

(7) Repeat (f)(1) to ensure that the burner is in the correct range.

(g) *Test Procedure*

(1) Mount a thermocouple of the same type as that used for calibration at a distance of 101 mm (4 inches) above the horizontal (ceiling) test specimen. The thermocouple should be centred over the burner cone.

(2) Mount the test specimen on the test stand shown in Figure 1 in either the horizontal or vertical position. Mount the insulating material in the other position.

(3) Position the burner so that flames will not impinge on the specimen, turn the burner on, and allow it to run for 2 minutes. Rotate the burner to apply the flame to the specimen and simultaneously start the timing device.

(4) Expose the test specimen to the flame for 5 minutes and then turn off the burner. The test may be terminated earlier if flame penetration is observed.

(5) When testing ceiling liner panels, record the peak temperature measured 101.6 mm (4 inches) above the sample.

(6) Record the time at which flame penetration occurs if applicable.

(h) *Test Report.* The test report must include the following:

(1) A complete description of the materials tested including type, manufacturer, thickness, and other appropriate data.

(2) Observations of the behaviour of the test specimens during flame exposure such as delamination, resin ignition, smoke, etc., including the time of such occurrence.

(3) The time at which flame penetration occurs, if applicable, for each of three specimens tested.

(4) Panel orientation (ceiling or sidewall).

Appendix F (Part III) (continued)

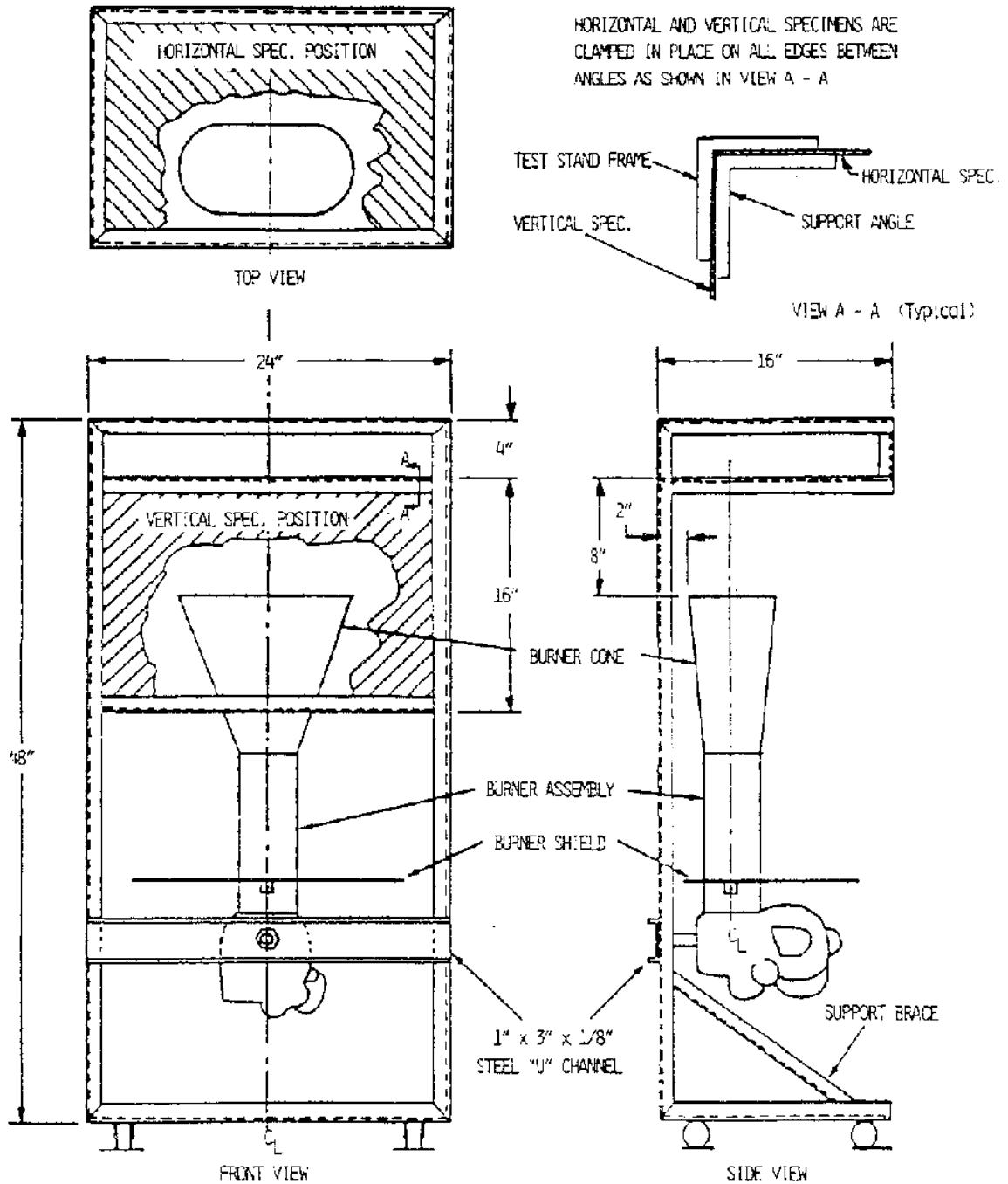

TEST STAND IS CONSTRUCTED WITH 1" x 1" x 1/8" STEEL ANGLES. ALL JOINTS WELDED  
 SUPPORT ANGLES ARE 1" x 1" x 1/8" CUT TO FIT

FIGURE 1 - TEST APPARATUS FOR HORIZONTAL AND VERTICAL MOUNTING

Appendix F (Part III) (continued)

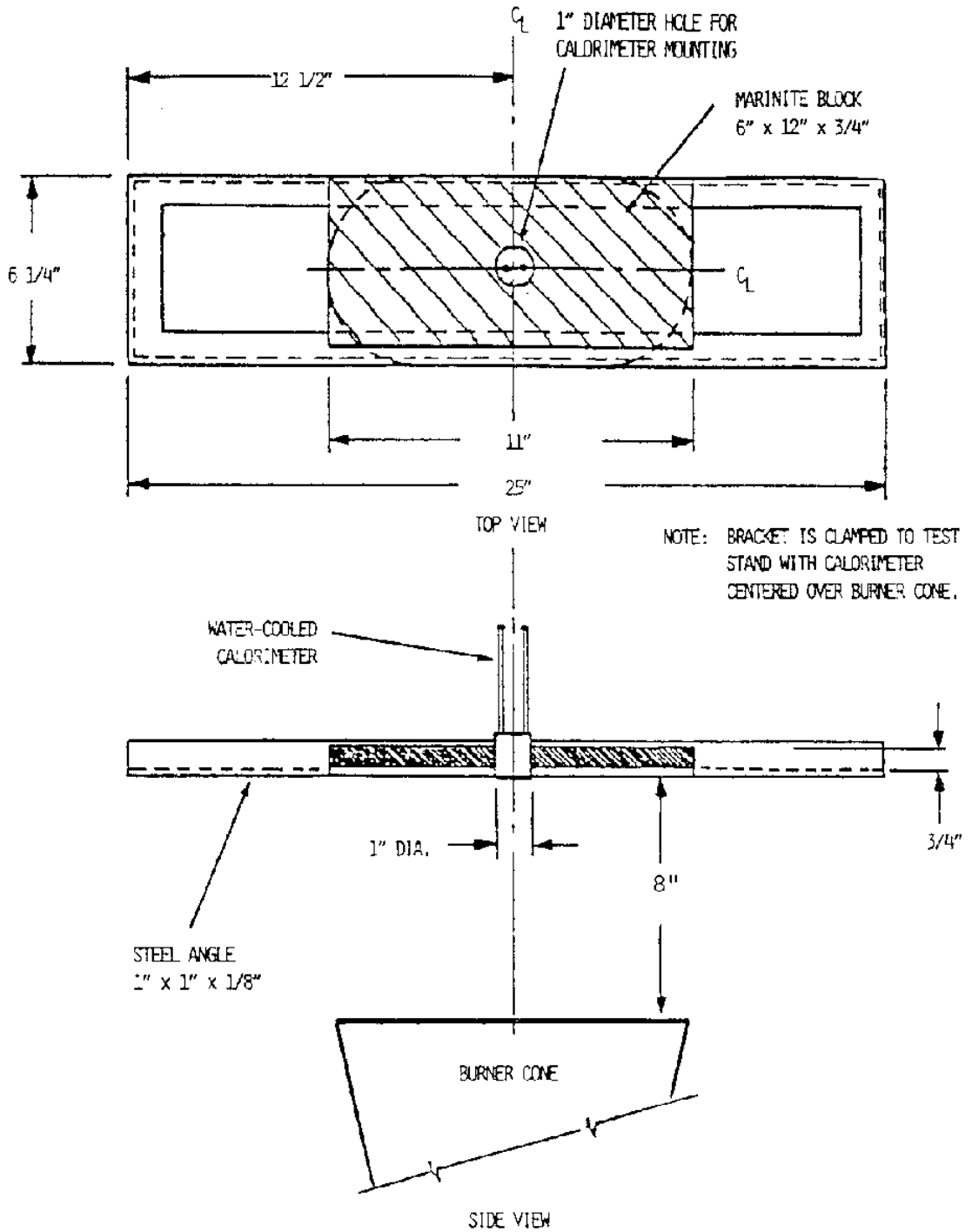
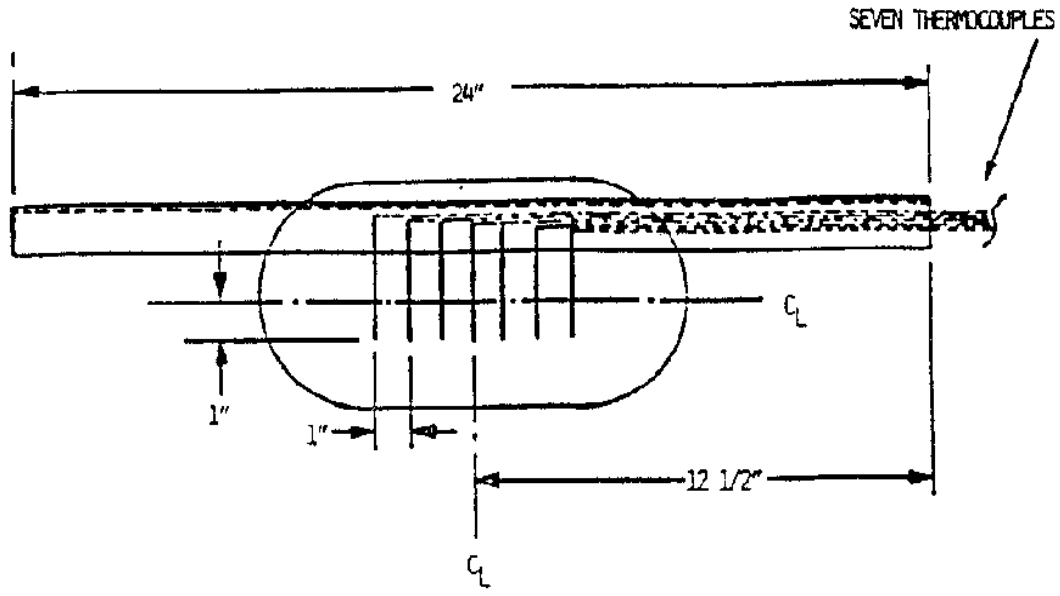

FIGURE 2 - CALORIMETER BRACKET



NOTE: BRACKET IS CLAMPED TO TEST STAND WITH THERMOCOUPLES OFF CENTER OF BURNER CONE BY ONE INCH.

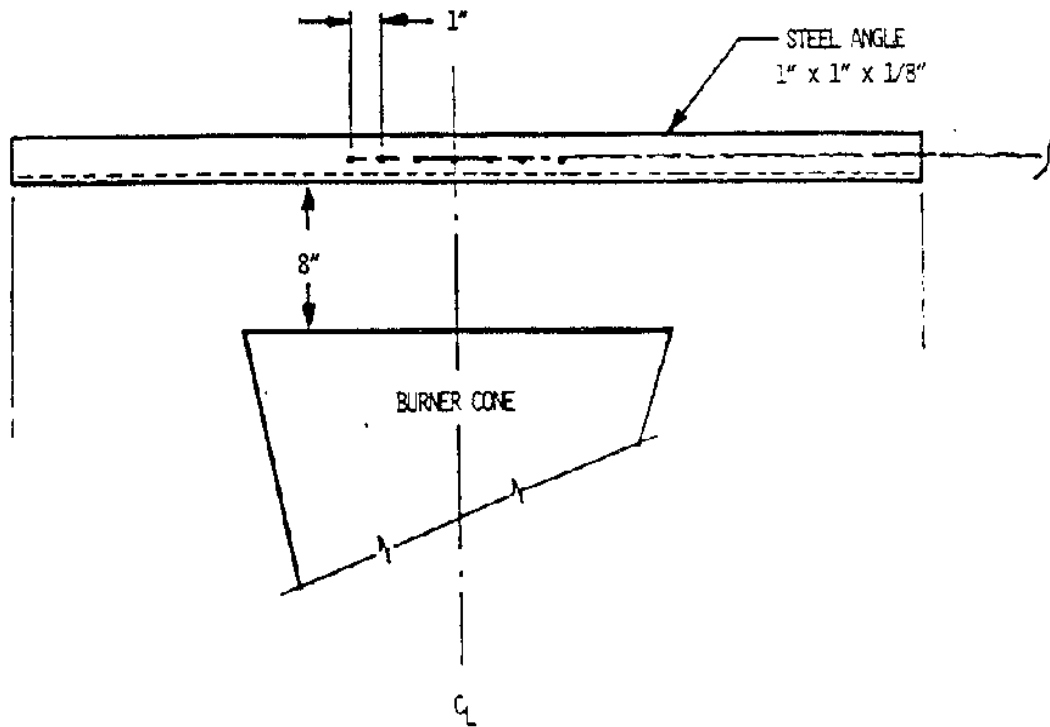

FIGURE 3 - THERMOCOUPLE RAKE BRACKET

**Appendix F (continued)**  
**Part IV – Test Method to Determine the Heat Release Rate From Cabin Materials Exposed to Radiant Heat**

(See ACJ Appendix F, Part IV)

Text derived from: JAR-25 Appendix F, Part IV at Chg 13, 05/10/89

(a) *Summary of Method*

(1) The specimen to be tested is injected into an environmental chamber through which a constant flow of air passes. The specimen's exposure is determined by a radiant heat source adjusted to produce the desired total heat flux on the specimen of 3.5 Watts/cm<sup>2</sup>, using a calibrated calorimeter. The specimen is tested so that the exposed surface is vertical. Combustion is initiated by piloted ignition. The combustion products leaving the chamber are monitored in order to calculate the release rate of heat.

(b) *Apparatus.* The Ohio State University (OSU) rate of heat release apparatus as described below, is used. This is a modified version of the rate of heat release apparatus standardised by the American Society of Testing and Materials (ASTM), ASTM E-906.

(1) This apparatus is shown in Figure 1. All exterior surfaces of the apparatus, except the holding chamber, shall be insulated with 25 mm (1 inch) thick, low density, high-temperature, fibreglass board insulation. A gasketed door through which the sample injection rod slides forms an airtight closure on the specimen hold chamber.

(2) *Thermopile.* The temperature difference between the air entering the environmental chamber and that leaving is monitored by a thermopile having five hot and five cold, 24 gauge Chromel-Alumel junctions. The hot junctions are spaced across the top of the exhaust stack 10 mm (0.39 inch) below the top of the chimney. One thermocouple is located in the geometric centre, with the other four located 30 mm (1.17 inch) from the centre along the diagonal toward each of the corners (Figure 5). The cold junctions are located in the pan below the lower air distribution plate (see sub-paragraph (b)(4)). Thermopile hot junctions must be cleared of soot deposits as needed to maintain the calibrated sensitivity.

(3) *Radiation Source.* A radiant heat source for generating a flux up to 100 kW/m<sup>2</sup>, using four silicon carbide elements, Type LL, 50.8 cm (20 inches) long by 15.8 mm (0.625 inch) O.D., nominal resistance 1.4 ohms, is shown in Figures 2A and 2B.

The silicon carbide elements are mounted in the stainless steel panel box by inserting them through 15.9 mm holes in 0.8 mm thick ceramic fibre board. Location of the holes in the pads and stainless steel cover plates are shown in Figure 2B. The diamond shaped mask of 19 gauge stainless steel is added to provide uniform heat flux over the area occupied by the 150 by 150 mm vertical sample.

(4) *Air Distribution System.* The air entering the environmental chamber is distributed by a 6.3 mm thick aluminium plate having eight, No. 4 drill holes, 51 mm from sides on 102 mm centres, mounted at the base of the environmental chamber. A second plate of 18 gauge steel having 120, evenly spaced, No. 28 drill holes is mounted 150 mm above the aluminium plate. A well-regulated air supply is required. The air supply manifold at the base of the pyramidal section has 48, evenly spaced, No. 26 drill holes located 10 mm from the inner edge of the manifold so that 0.03 m<sup>3</sup>/second of air flows between the pyramidal sections and 0.01 m<sup>3</sup>/second flows through the environmental chamber when total air flow to apparatus is controlled at 0.04 m<sup>3</sup>/second.

(5) *Exhaust Stack.* An exhaust stack, 133 mm by 70 mm in cross section, and 254 mm long, fabricated from 28 gauge stainless steel, is mounted on the outlet of the pyramidal section. A 25 mm by 76 mm plate of 31 gauge stainless steel is centred inside the stack, perpendicular to the air flow, 75 mm above the base of the stack.

(6) *Specimen Holders.* The 150 mm x 150 mm specimen is tested in a vertical orientation. The holder (Figure 3) is provided with a specimen holder frame, which touches the specimen (which is wrapped with aluminium foil as required by sub-paragraph (d)(3)) along only the 6 mm perimeter, and a "V" shaped spring to hold the assembly together. A detachable 12 mm x 12 mm x 150 mm drip pan and two 0.020 inch stainless steel wires (as shown in Figure 3) should be used for testing of materials prone to melting and dripping. The positioning of the spring and frame may be changed to accommodate different specimen thicknesses by inserting

## Appendix F (Part IV) (continued)

the retaining rod in different holes on the specimen holder.

Since the radiation shield described in ASTM E-906 is not used, a guide pin is added to the injection mechanism. This fits into a slotted metal plate on the injection mechanism outside of the holding chamber and can be used to provide accurate positioning of the specimen face after injection. The front surface of the specimen shall be 100 mm from the closed radiation doors after injection.

The specimen holder clips onto the mounted bracket (Figure 3). The mounting bracket is attached to the injection rod by three screws which pass through a wide area washer welded onto a 0.5 inch nut. The end of the injection rod is threaded to screw into the nut and a 0.020 inch thick wide area washer is held between two 0.5 inch nuts which are adjusted to tightly cover the hole in the radiation doors through which the injection rod or calibration calorimeter pass.

(7) *Calorimeter.* A total-flux type calorimeter must be mounted in the centre of a 0.5 inch Kaowool "M" board inserted in the sample holder must be used to measure the total heat flux. The calorimeter must have a view angle of 180° and be calibrated for incident flux. The calorimeter calibration must be acceptable to the Authority.

(8) *Pilot-Flame Positions.* Pilot ignition of the specimen must be accomplished by simultaneously exposing the specimen to a lower pilot burner and an upper pilot burner, as described in sub-paragraphs (b)(8)(i) and (b)(8)(ii), respectively. The pilot burners must remain lighted for the entire 5-minute duration of the test.

(i) *Lower Pilot Burner.* The pilot-flame tubing must be 6.3 mm O.D., 0.8 mm wall, stainless steel tubing. A mixture of 120 cm<sup>3</sup>/min. of methane and 850 cm<sup>3</sup>/min. of air must be fed to the lower pilot flame burner. The normal position of the end of the pilot burner tubing is 10 mm from and perpendicular to the exposed vertical surface of the specimen. The centreline at the outlet of the burner tubing must intersect the vertical centreline of the sample at a point 5 mm above the lower exposed edge of the specimen.

(ii) *Upper Pilot Burner.* The pilot burner must be a straight length of 6.3 mm O.D., 0.8 mm wall, stainless steel tubing 360 mm long. One end of the tubing shall be closed, and three No. 40 drill holes shall be drilled into the tubing, 60 mm apart, for gas ports, all radiating in the same direction. The first hole must be 5 mm from the closed end of the tubing. The tube is inserted into the environmental chamber through a 6.6 mm hole drilled 10 mm above the upper edge of the window frame. The tube is supported and positioned by an adjustable "Z" shaped support mounted outside the environmental chamber, above the viewing window. The tube is positioned above and 20 mm behind the exposed upper edge of the specimen. The middle hold must be in the vertical plane perpendicular to the exposed surface of the specimen which passes through its vertical centreline and must be pointed toward the radiation source. The gas supplied to the burner must be methane adjusted to produce flame lengths of 25 mm.

(c) *Calibration of Equipment*

(1) *Heat Release Rate.* A burner as shown in Figure 4 must be placed over the end of the lower pilot flame tubing using a gas-tight connection. The flow of gas to the pilot flame must be at least 99% methane and must be accurately metered. Prior to usage, the wet test meter is properly levelled and filled with distilled water to the tip of the internal pointer while no gas is flowing. Ambient temperature and pressure of the water, are based on the internal wet test meter temperature. A baseline flow rate of approximately 1 litre/min. is set and increased to higher preset flows of 4, 6, 8, 6 and 4 litres/min. The rate is determined by using a stopwatch to time a complete revolution of the wet test meter for both the baseline and higher flow, with the flow returned to baseline before changing to the next higher flow. The thermopile baseline voltage is measured. The gas flow to the burner must be increased to the higher preset flow and allowed to burn for 2.0 minutes, and the thermopile voltage must be measured. The sequence is repeated until all five values have been determined. The average of the five values must be used as the calibration factor.

## Appendix F (Part IV) (continued)

The procedure must be repeated if the percent relative standard deviation is greater than 5%. Calculations are shown in paragraph (f).

(2) *Flux Uniformity*. Uniformity of flux over the specimen must be checked periodically and after each heating element change to determine if it is within acceptable limits of  $\pm 5\%$ .

(d) *Sample Preparation*

(1) The standard size for vertically mounted specimens is 150 x 150 mm with thicknesses up to 45 mm.

(2) *Conditioning*. Specimens must be conditioned as described in Part I of this Appendix.

(3) *Mounting*. Only one surface of a specimen will be exposed during a test. A single layer of 0.025 mm aluminium foil is wrapped tightly on all unexposed sides.

(e) *Procedure*

(1) The power supply to the radiant panel is set to produce a radiant flux of 3.5 Watts/cm<sup>2</sup>. The flux is measured at the point which the centre of the specimen surface will occupy when positioned for test. The radiant flux is measured after the air flow through the equipment is adjusted to the desired rate. The sample should be tested in its end use thickness.

(2) The pilot flames are lighted and their position, as described in sub-paragraph (b)(8), is checked.

(3) The air flow to the equipment is set at  $0.04 \pm 0.001$  m<sup>3</sup>/s at atmospheric pressure. Proper air flow may be set and monitored by either: (1) An orifice meter designed to produce a pressure drop of at least 200 mm of the manometric fluid, or by (2) a rotometer (variable orifice meter) with a scale capable of being read to  $\pm 0.0004$  m<sup>3</sup>/s. The stop on the vertical specimen holder rod is adjusted so that the exposed surface of the specimen is positioned 100 mm from the entrance when injected into the environmental chamber.

(4) The specimen is placed in the hold chamber with the radiation doors closed. The airtight outer door is secured, and the recording devices are started. The specimen must be retained in the hold chamber for 60 seconds  $\pm$  10 seconds, before injection.

The thermopile "zero" value is determined during the last 20 seconds of the hold period.

(5) When the specimen is to be injected, the radiation doors are opened, the specimen is injected into the environmental chamber, and the radiation doors are closed behind the specimen.

(6) Reserved.

(7) Injection of the specimen and closure of the inner door marks time zero. A continuous record of the thermopile output with at least one data point per second must be made during the time the specimen is in the environmental chamber.

(8) The test duration time is five minutes.

(9) A minimum of three specimens must be tested.

(f) *Calculations*

(1) The calibration factor is calculated as follows:

$$K_h = \frac{(F_1 - F_0)}{(V_1 - V_0)} \times \frac{(210.8 - 22) \text{ kcal}}{\text{mole}} \times \frac{273}{T_a} \times \frac{P - P_v}{760} \times \frac{\text{mole CH}_4 \text{ STP}}{22.41} \times \frac{\text{WATT.min}}{.01433 \text{ kcal}} \times \frac{\text{kW}}{1000 \text{ W}}$$

$F_0$  = Flow of methane at baseline (1pm)

$F_1$  = Higher preset flow of methane (1pm)

$V_0$  = Thermopile voltage at baseline (mv)

$V_1$  = Thermopile voltage at higher flow (mv)

$T_a$  = Ambient temperature (K)

$P$  = Ambient pressure (mm Hg)

$P_v$  = Water vapour pressure (mm Hg)

(2) Heat release rates may be calculated from the reading of the thermopile output voltage at any instant of time as:

$$\text{HRR} = \frac{V_m - V_b}{.02323 \text{ m}^2} \times K_h$$

HRR = Heat Release Rate kW/m<sup>2</sup>

$V_m$  = Measured thermopile voltage (mv)

$V_b$  = Baseline voltage (mv)

$K_h$  = Calibration Factor (kW/mv)

(3) The integral of the heat release rate is the total heat release as a function of time and is calculated by multiplying the rate by the data sampling frequency in minutes and summing the time from zero to two minutes.

## Appendix F (Part IV) (continued)

(g) *Criteria.* The total positive heat release over the first two minutes of exposure for each of the three or more samples tested must be averaged, and the peak heat release rate for each of the samples must be averaged. The average total heat release must not exceed 65 kilowatt-minutes per square metre, and the average peak heat release rate must not exceed 65 kilowatts per square metre.

(h) *Report.* The test report must include the following for each specimen tested:

- (1) Description of the specimen.
- (2) Radiant heat flux to the specimen, expressed in Watts/cm<sup>2</sup>.
- (3) Data giving release rates of heat (in kW/m<sup>2</sup>) as a function of time, either graphically or tabulated at intervals no greater than 10 seconds. The calibration factor must be recorded.
- (4) If melting, sagging, delaminating, or other behaviour that affects the exposed surface area or the mode of burning occurs, these behaviours must be reported, together with the time at which such behaviours were observed.
- (5) The peak heat release and the 2 minute integrated heat release rate must be reported.

INTENTIONALLY LEFT BLANK

Appendix F (Part IV) (continued)

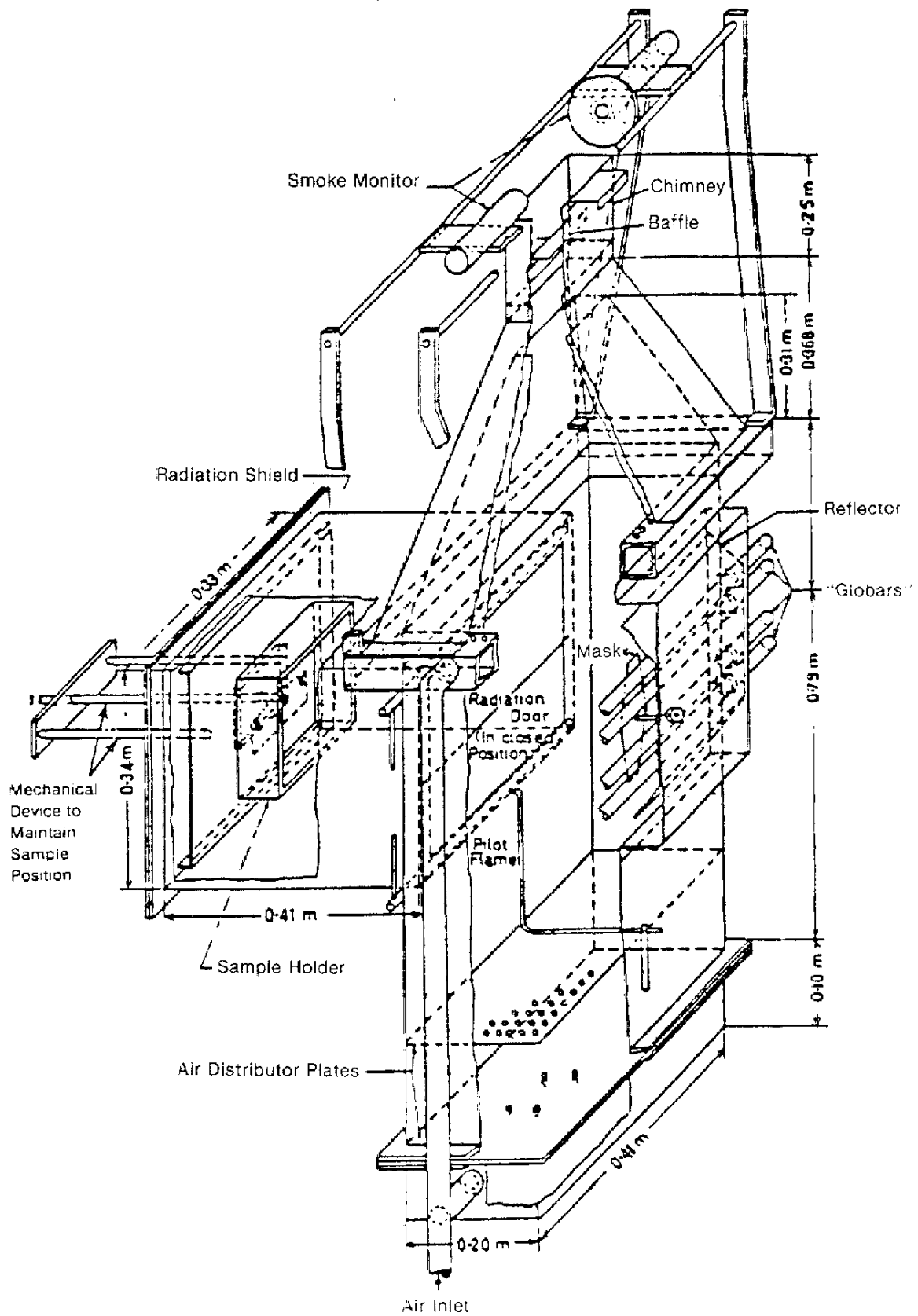
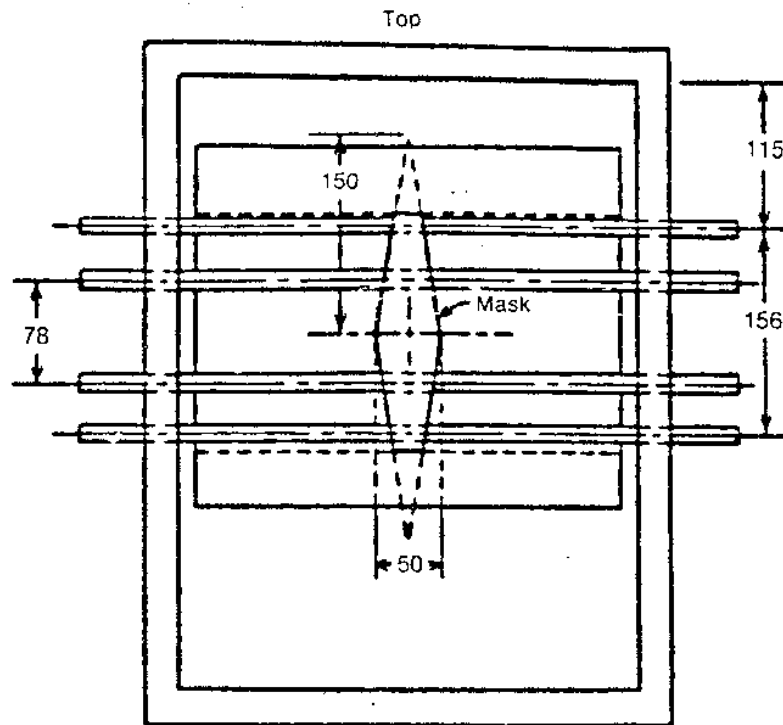

FIGURE 1 - RELEASE RATE APPARATUS

Appendix F (Part IV) (continued)



(Unless denoted otherwise, all dimensions are in millimeters.)

FIGURE 2A - "GLOBAR" RADIANT PANEL

Appendix F (Part IV) (continued)

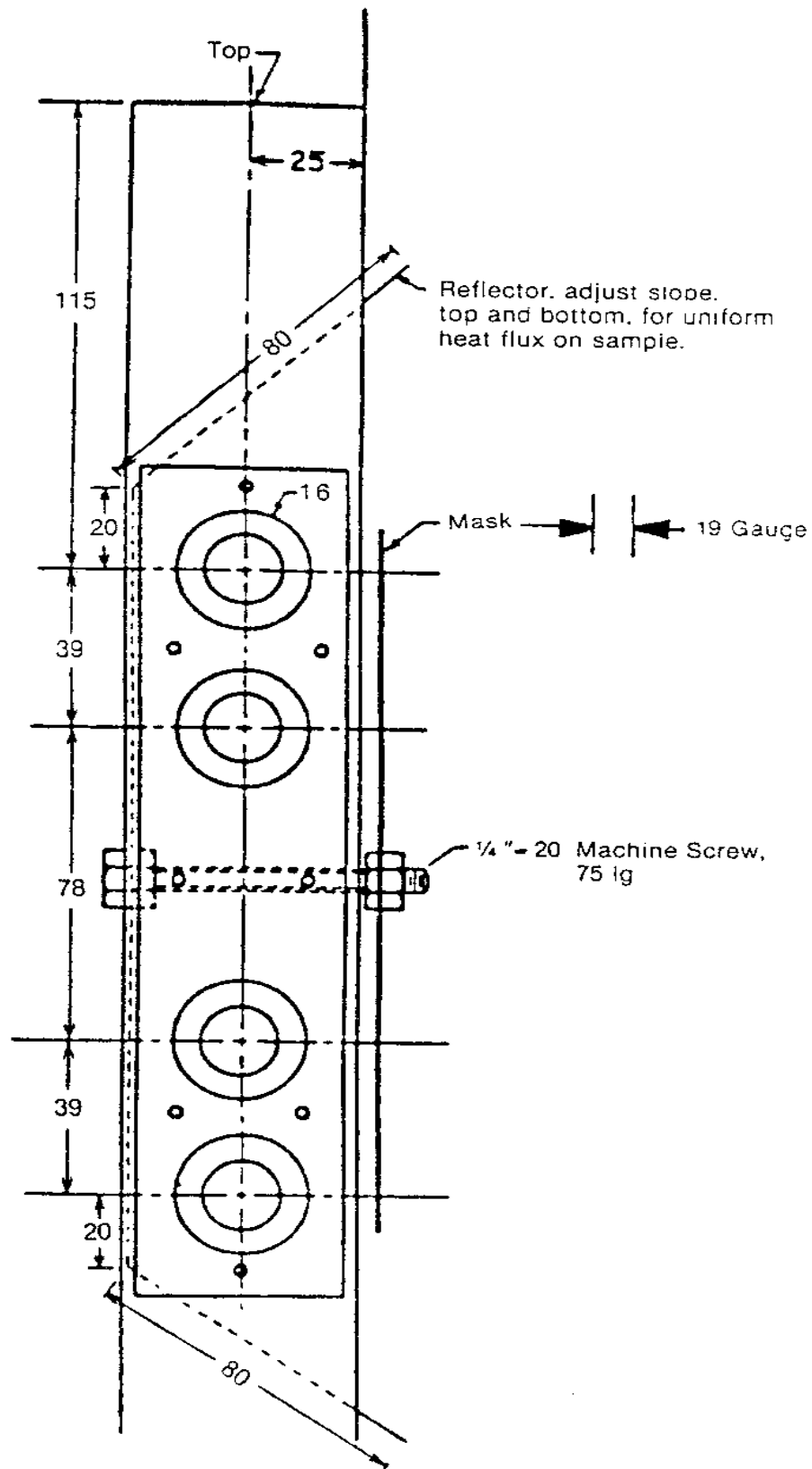

(Unless denoted otherwise, all dimensions are in millimeters.)

FIGURE 2B - "GLOBAR" RADIANT PANEL

Appendix F (Part IV) (continued)

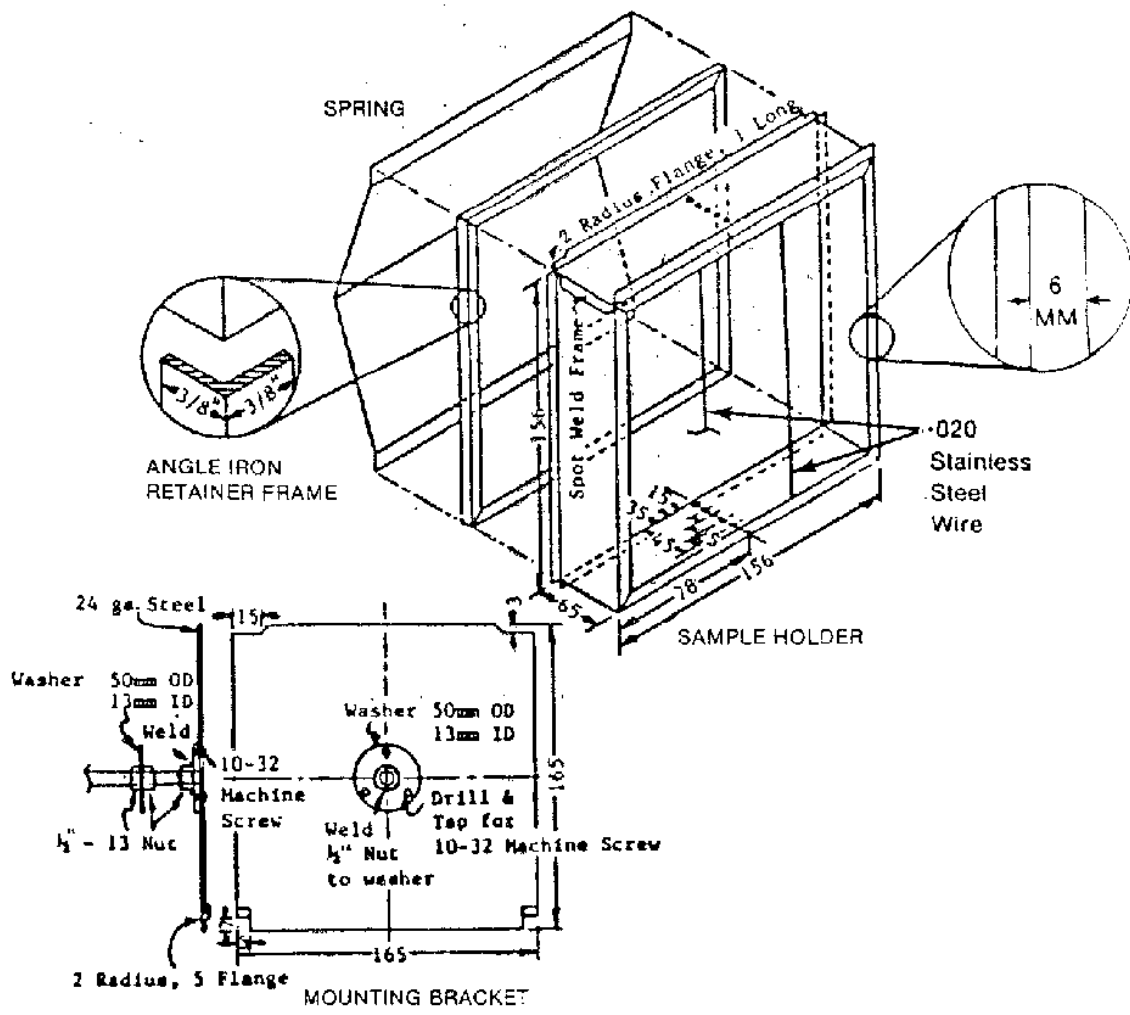

(Unless denoted otherwise, all dimensions are in millimeters.)

FIGURE 3

Appendix F (Part IV) (continued)

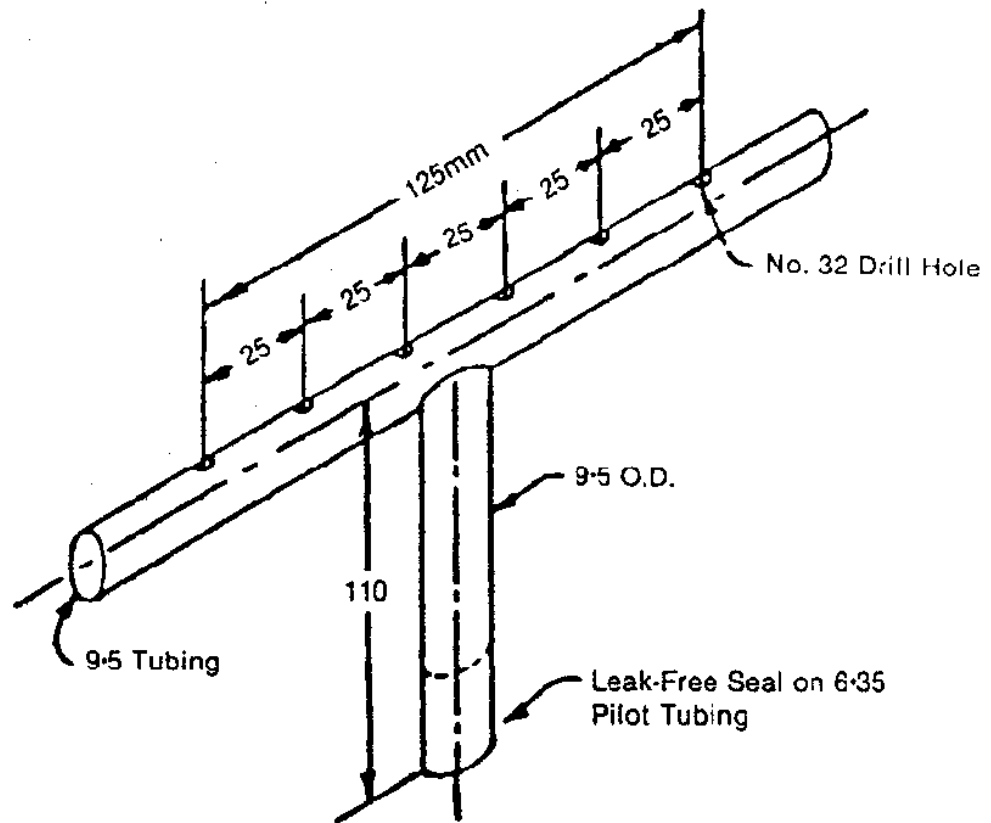

(Unless denoted otherwise, all dimensions are in millimeters.)

FIGURE 4

Appendix F (Part IV) (continued)

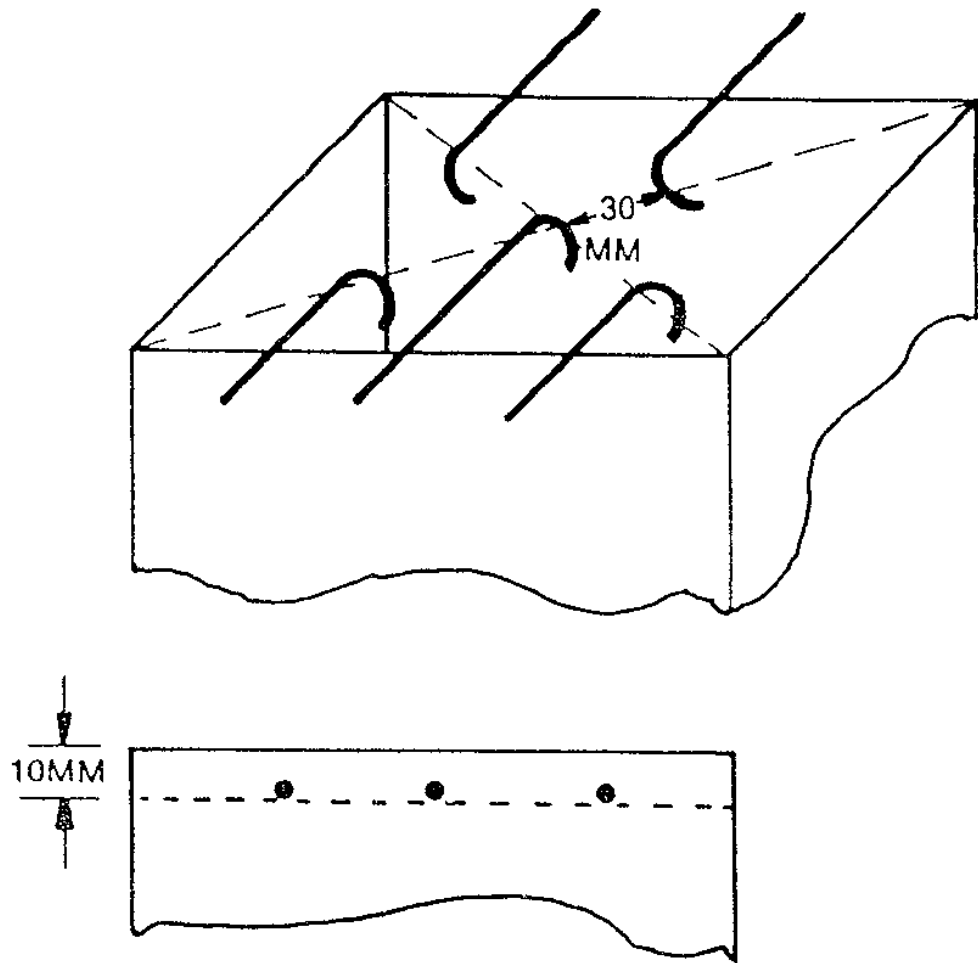

FIGURE 5 – THERMOCOUPLE POSITION

**Appendix F (continued)****Part V – Test Method to Determine the Smoke Emission Characteristics of Cabin Materials**

Text derived from: JAR-25 Appendix F, Part V at Chg 13, 05/10/89

(a) *Summary of Method.* The specimens must be constructed, conditioned, and tested in the flaming mode in accordance with American Society of Testing and Materials (ASTM) Standard Test Method ASTM F814-83.

(b) *Acceptance Criteria* The specific optical smoke density (DS) which is obtained by averaging the reading obtained after 4 minutes with each of the three specimens, shall not exceed 200.

INTENTIONALLY LEFT BLANK

INTENTIONALLY LEFT BLANK

**SUBPART C – GENERAL AVIATION (AEROPLANES)**  
[Reserved]

INTENTIONALLY LEFT BLANK

INTENTIONALLY LEFT BLANK

**SUBPART D – COMMERCIAL AIR TRANSPORTATION (HELICOPTERS)**  
[Reserved]

INTENTIONALLY LEFT BLANK

INTENTIONALLY LEFT BLANK

**SUBPART E – GENERAL AVIATION (HELICOPTERS)**  
[Reserved]

INTENTIONALLY LEFT BLANK

INTENTIONALLY LEFT BLANK